

Marine Equipment Directive
(MED) 2014/90/EU MED



New FSP127 Complete kit shown



APPLICATION

The FRANCIS FSP 127 (MKV) signalling lantern fulfils the requirements and is fully approved to the MED Regulations and SOLAS, which states that "all ships of over 150 tons gross tonnage, when engaged on International voyages, shall have onboard an efficient daylight signalling lamp which shall not be solely dependent upon the ship's main source of electrical power." The 127mm (5") handheld signalling light can be used on all vessels, for ship to ship signalling using Morse Code. The light is of aluminium, lightweight and robust construction and is fully waterproof. If desired this unit can be used as a spotlight if the signalling trigger and lamp switch are both left on. The Francis Signalling Lantern is approved by the UK Maritime & Coastguard Agency (MCA.)

SPECIFICATION

- Capable of daylight signalling range of 8 miles.
- Beam divergence of 5°.
- Transmission rate of 12 words per minute achievable
- Light reduction & coloured filters provide control of light output as required.
- 5.5 metres of supply cable fitted as standard.
- All aluminium construction, fitted with a super purity aluminium parabolic reflector.
- Tubular and V sights are fitted as standard.
- Handle mounted switch to operate the lantern
- Signals made by triggering the tubular shutter system which interrupts the light from the reflector.
- Semi gloss black stoved enamel paint finish.

Product	Type	Desp No	NSN
FSP127	Commercial	A4023	6210-99-799-0880
FSP127	MoD	A4021	5850-99-527-7235

Weight 2.2 Kg

** As per MED / SOLAS requirements, each lantern should be supplied with 3 spare lamps and an approved portable battery pack. **

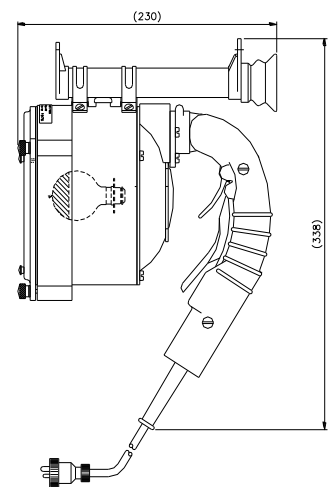
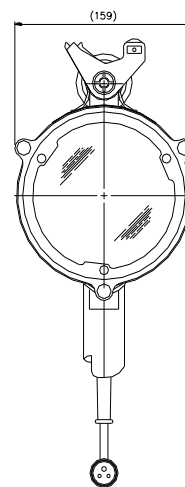

Description	Despatch No.	Weight
Complete Lantern kit 24v 3Pin	A6133	13 kg
Complete Lantern Kit 12v 3Pin	A6134	13 kg
Complete Lantern Kit 24v 2Pin	A6146	13 kg
Complete Lantern Kit 12v 2Pin	A6147	13 kg

The Complete Kit solution includes:
High quality Polypropylene carrying case with bespoke foam inserts & integrated charging socket, 4 lamps, battery in case, switch mode battery charger, and red /green coloured filter set.

Accessories	Despatch No.	Weight
11v 60w Lamp	D1721	
24v 60w Lamp	D1754	
Carrying Case PP Assy	C26666-01	4.0 Kg
Stowage Box (Aluminium)	A4025	9.9 Kg
12v Battery in case	C20175-01	5.8 Kg
24v Battery in case	C20177-01	5.8 Kg
12v Battery Charger (115/230v)	C26664-01	0.10 Kg
24v Battery Charger (115/230v)	C26665-01	0.10 Kg
Light Reduction Screen	C03194-01	143 g
Red Filter	C05971-01	103 g
Green Filter	C05973-01	103 g
Blue Filter	C09901-01	103 g
Transformer Unit	C20189-00	2.0 kg
115v/230v in 12v/24v out		

BATTERY PACK

- C20174-01 12v Battery Case 2 Pin - MoD
- C20175-01 12v Battery Case 3 Pin - Commercial
- C20176-01 24v Battery Case 2 Pin - MoD
- C20177-01 24v Battery Case 3 Pin - Commercial

Weight 5.8Kg.

- Battery 12 volt 7 amp hour.
- Battery Life (12v) 80 minutes continuous use.
- Battery Life (24v) 115 minutes continuous use.
- Battery Life (12/24V) 2 Hours (signalling).
- Valve Regulated Lead Acid Battery.
- Available with 2 or 3 Pin Sockets.

Transport Safety Document - Request from Sales QATO2-B

Approved to the Marine Equipment Directive (MED) 2014/90/EU MED

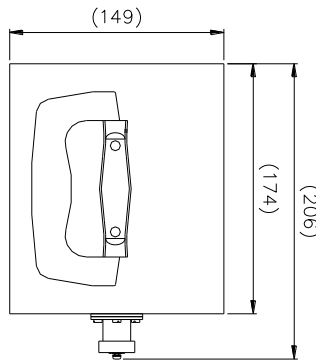

New battery pack with LED status monitor

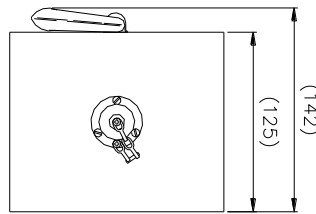

CHARGER



- C26664-01 12v Battery Charger 3 Pin - Commercial
- C26665-01 24v Battery Charger 3 Pin - Commercial
- C26750-01 12v Battery Charger 2 Pin - MoD
- C26751-01 24v Battery Charger 2 Pin - MoD

Charge Rate :-
 12v 14.7v @ 1 amp
 24v 29.4v @ 0.5 amp

Intelligent switch mode battery charger with dual input 115 / 230v

CARRYING CASE



High quality Polypropylene Carrying Case complete with integrated charging socket and bespoke foam inserts for maximum protection.

- C26666-01 Carry case PP 550 x 420 x 211 mm Weight 4kg
- A4026 Carrying Case MOD NSN6230-99-462-4201

FILTERS

- | | |
|----------------------------------|---------------------|
| C05971-01 Red Filter Assy | NSN5850-99-527-1297 |
| C05973-01 Green Filter Assy | NSN6210-99-783-0401 |
| C09901-01 Blue Filter Assy | NSN5850-99-794-2670 |
| C21728-01 Yellow Filter Assy | |
| C23433-01 Amber Filter Assy | |
| Weight 103gms each | |
| C03194-01 Light Reduction Screen | NSN6210-99-780-5544 |
| Weight 141 gms | |

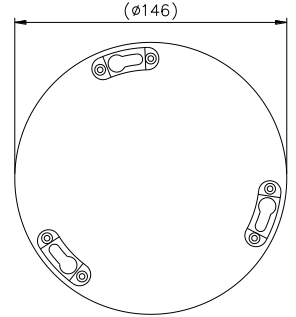

TRANSFORMER

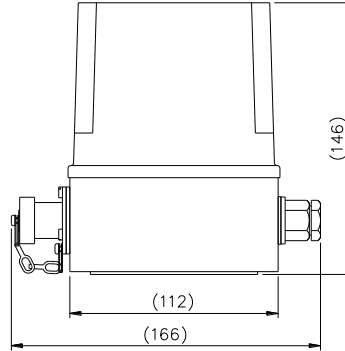
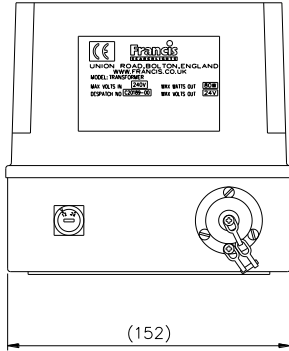

- | | |
|--|------------|
| C20189-01 Step Down Transformer Unit 115v/230v in 12/24v out 3 Pin | Weight 2Kg |
| C23619-01 Step Down Transformer Unit 115v/230v in 12/24v out 2 Pin | Weight 2Kg |

PLUG & SOCKET – COMMERCIAL



Chrome Plated Brass Connector with Sealing Ring and Cap.

- | | | |
|-----------------------------------|--------|-----|
| C02682-00 3 Pin Plug 5amp | Weight | 42g |
| C02681-00 3 Pin Socket & Cap 5amp | Weight | 56g |

Plug 26mm diameter x 41mm Long (Including Pins)
 Socket 36mm diameter x 32mm Long (Including Gasket & Cap)

PLUG & SOCKET - MoD



Nickel Plated Brass Connector with Sealing Ring and Cap

C03012-01 2 Pin Plug 5amp	Wgt 43g	NSN5935-99-427-7272
C03599-01 2 Pin Socket & Cap 5amp	Wgt 69g	NSN5935-99-427-7273

Plug 22mm A/F x 54mm Long (Including Pins)
 Socket 41mm diameter x 33mm Long (Including Gasket & Cap)

STOWAGE BOX - MoD

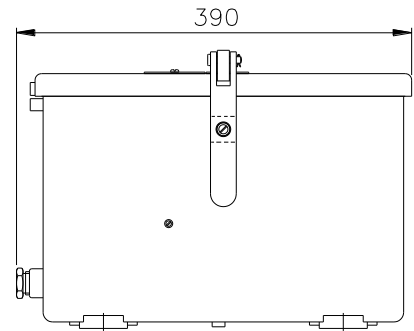
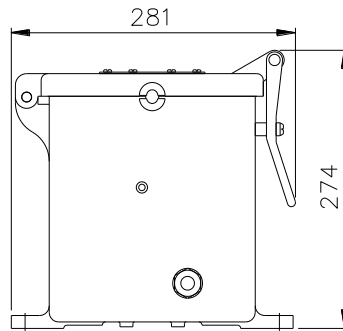

A4025 Stowage Box Weight 9.9Kg NSN6230-99-462-4204



D1721	11v 60w Lamp	P30D	NSN6240.099.995.2513
D1754	24v 60w Lamp	P15D	NSN6240.099.995.2515

For more information contact: