

- Pendant or upright mounting options.
- Beam alignment adjustable (spring mounted).
- Pre-treatment and paint finish in accordance with MVEE 666.
- Base fixing stem machined to accept a "Silentbloc" mounting.
- Standard paint finish BS381C Colour No. 224, deep bronze green.

## Specifications

Designed for use on armoured fighting vehicles, the 1826 series driving lights are fitted with a 115mm (4½") diameter, dual filament 28V sealed beam light unit. The sealed beam unit is spring mounted into a robust aluminium die-cast body.

A clear lens is incorporated into the front rim assembly in order to give additional protection to the sealed beam unit. The driving light is waterproof.

## Additional features

- Base fixing stem machined to accept a "Silentbloc" mounting.
- Pendant or upright mounting options (see table).
- Pre-wired internally to a military approved connector type 14S-2P (FV585003) terminating at rear of body.
- Pre-treatment and paint finish in accordance with MVEE 666.
- Standard paint finish BS381C Colour No. 224, deep bronze green.
- Beam alignment adjustable (spring mounted).
- Weight 2.44kg.

## 1826 Series Driving Lights

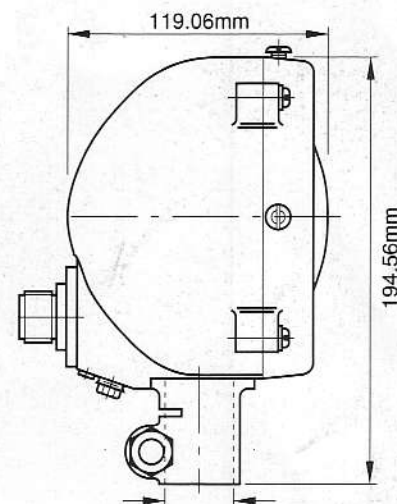
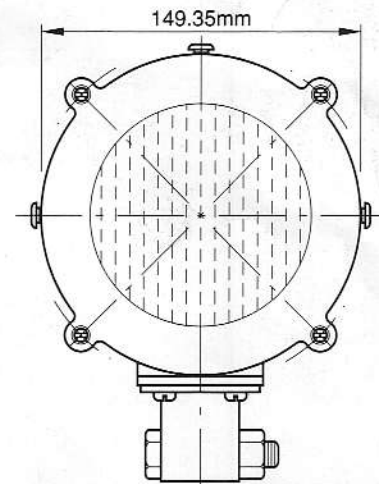

FIXING STEM INTERNAL  
DIAMETER 28.70mm (1.130")

## Product Information

Model	FV N°.	N°.	Mk.	NSN 6MT3/6220-99	Volts	Watts	Mounting	Francis Despatch N°.
1826A	861118	3	3	802-8100	28	110/55	UPRIGHT	B7352
1826C	861119	3	4	829-9619	28	110/55	PENDANT	B7353
1826D	861126	3	5	826-8259	28	110/55	PENDANT-LESS FIXING STEM	B7350