



User Instruction & Installation Manual
LX230RC Remote Focus 100 Watt
HID Xenon Searchlight



Product Reference Number:

A7205 - LX230RC 24v
A7206 - LX230RC 220v
A7207 - LX230RC 115v

Manufacturer's details:

Francis Searchlights Ltd
Union Road, Bolton
Lancashire, BL2 2HJ, UK
Tel: +44 (0) 1204 558960
Fax: +44 (0) 1204 558979
<http://www.francis.co.uk>
E-mail: sales@francis.co.uk

Distributor details:

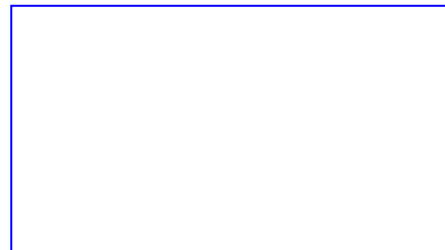

Manual Part Number: C27793

Issue: 1
2.4.19

CONTENTS

- 1 - Introduction
- 2 - Safety Precautions
- 3 - Technical Information
- 4 - Unpacking and Installation Instructions
- 5 - Electrical Installation
- 6 - Operating Instructions
- 7 - Fault Finding
- 8 - Maintenance and Servicing
- 9 - General Assembly and Wiring Diagrams
- 10 - Spare Parts List

1 - Introduction

It is imperative that this manual is read carefully and understood before installing your equipment. For your future reference please keep this manual in a safe place.

Thank you for specifying a product from the Francis Searchlights range. All Francis products are designed to give complete customer satisfaction and are manufactured to the highest engineering standards in order to ensure optimum performance and service life.

The Francis Xenon range combines features proven over many years service in the most hazardous conditions in both marine and land installations.

In order to prolong the life and performance of your product, we recommend that you only specify Francis Searchlights spare parts. This will also ensure that any warranties on your equipment will not be invalidated. Information on spares ordering and parts is provided in this manual.

Should you ever need to contact Francis Searchlights Ltd. regarding your equipment, please quote the Product Serial Number at all times.

2 - Safety Precautions

The following instructions must be adhered to, in order to ensure a safe working environment and the safety of the user.

Note: When unpacking or manoeuvring the searchlight into its fixing position, suitable lifting points must be used in order to prevent damage to the equipment or personal injury.

- Because of the high internal pressure within the lamp, there is a risk of explosion in either a hot or cold state.
- During operation this lamp emits intense UV radiation which is harmful to the eyes and skin. Suitable protection should be worn.
- The high luminance of the arc can cause severe damage to the eye if viewed directly. ALWAYS wear suitable protective goggles when viewing the lamp.
- Always use protective sleeves supplied with the lamp whilst handling.
- Should it be necessary to examine the lamp with the front bezel removed, always use a protective shield and wear goggles to ensure a safe working environment.
- Searchlights get hot. Never touch the unit when lit and always allow 15 to 20 minutes for cooling down after turning the searchlight off.
- Never place anything on or cover the searchlight when in use.
- Ensure the lamp has cooled sufficiently before removal.
- If undue force appears necessary to remove the lamp, the equipment should be inspected by a competent person or contact the manufacturer.
- When disposing of lamps, return the lamp, via the supplier, to the lamp manufacturer in its complete packaging.
- Due to the vast range of lamps available it may appear possible that more powerful lamps can be used in the equipment than for which it was designed. Even when the unit will physically accept a higher wattage or voltage lamp, this substitution is not recommended and is dangerous. This action will also void any warranties on the equipment.
- Always refer to the lamp manufacturer's technical data when dealing with lamps.

3 – Technical Information

This product has been designed to operate in accordance with the product specification. The LX230RC 100watt Remote Focus HID Xenon searchlight has the following features:

- All marine grade materials and fixings.
- Powder coated finish.
- Full 365° horizontal rotation.
- Vertical movement $\pm 20^\circ$.
- Pan rotation speed 24°/sec.
- Tilt rotation speed 4°/sec.
- Instant lamp re-strike. No cooling down time required.
- Economical 3000-hour lamp life.
- Toughened super clear Optiwhite front glass.
- Parabolic super pure aluminium reflector.
- Heater fitted in barrel.
- Remote focus as standard.
- Colour temperature 6000K.
- Sealing to IP66.
- Searchlight weight 11Kgs.

The searchlight also performs to the following optical data:

- Xenon HID light source
- Lamp Wattage - 100 Watts.
- Supply voltage – 9.5v to 30v DC or 115/240v AC.
- Peak Beam Candlepower – 3,100,000lux.
- Range – 1,761 metres.
- Adjustable lamp focus, 4° spot to 11° flood.
- Temperature range: -50°C

In order that the searchlight operates correctly it is imperative that competent personnel are responsible for the installation, operation and servicing of this equipment. Failure to adhere to this advice may cause premature failure or incorrect operation of the searchlight, which may damage the equipment or cause personal injury.

4 - Unpacking and Installation Instructions

The following instructions should be read and fully understood prior to installing the equipment to ensure that the correct procedures are followed, and all safety precautions are observed.

Note: If the equipment has been in storage for a considerable amount of time, it is advisable to conduct a routine maintenance check on all parts before installation.

Safety Precautions

This equipment should not be connected to an electrical supply before being installed. Installation procedures should be adhered to in order to ensure a safe working environment and reduce the risk of damage or personal injury.

Preparing the Mounting Position

Mark out and drill the fixing holes through the deck. If anti-vibration mounts are to be fitted, the fixing holes for the mounts should also be marked out and drilled. Prior to manoeuvring the searchlight into its' fixing position, the AV mounts should be fitted to the base.

Fit the 'O' ring in position and bolt the searchlight down securely. On an uneven surface it is necessary to use a suitable sealant, such as silicone, to ensure a weatherproofed joint.

5 - Electrical Installation

For safety purposes, only competent personnel should perform the electrical installation. All equipment should be installed to current Electrical Regulations and Standards.

In order to obtain the maximum light output from the searchlight, it is essential that the full operating voltage of the lamp fitted be applied to the lampholder contacts.

Method of Electrical Connection

- 1) Disconnect the supply before working on the electrical system.
- 2) The searchlight must be connected to a fused electrical supply, using suitably sized cable.
- 3) If the searchlight is located a considerable distance from the supply, provision must be made in the cable size in order to overcome the voltage drop.
- 4) Whenever possible cable terminations should be made below deck and with approved terminal devices.
- 5) If a spare auxiliary fuse or circuit breaker is not available, one of the correct type/rating should be fitted and connected to a positive supply. It is advisable to locate a bus bar or main connection and avoid any direct connection to the supply:

Installation Guidelines

A typical installation and connection routine for the LX230RC 240v Remote Focus searchlight is as follows:

Referring to wiring diagram C28161, a 240v supply is fed to the junction box, which then provides a 24v feed to the searchlight and joystick panel.
The searchlight has been pre-wired with 4 meters of cable from the searchlight to junction box provided (12 core 1.5mm cable).

Cables required to be connected by the customer: -
12 core 1.5mm cable from the joystick panel to the junction box.
3 core 1.5mm cable from the junction box to the joystick panel.
Supply cable to the junction box.

Installation Guidelines

A typical installation and connection routine for the LX230RC 110v Remote Focus searchlight is as follows:

Referring to wiring diagram C28162, a 110v supply is fed to the junction box, which then provides a 24v feed to the searchlight and joystick panel.
The searchlight has been pre-wired with 4 meters of cable from the searchlight to junction box provided (12 core 1.5mm cable).

Cables required to be connected by the customer: -
12 core 1.5mm cable from the joystick panel to the junction box.
3 core 1.5mm cable from the junction box to the joystick panel.
Supply cable to the junction box.

Installation Guidelines

A typical installation and connection routine for the LX230RC 24v Remote Focus searchlight is as follows:

Referring to wiring diagram C28163, a 24v supply is fed to the joystick panel.
The searchlight has been pre-wired with 4 meters of cable from the searchlight to junction box provided (12 core 1.5mm cable).

Cables required to be connected by the customer: -
12 core 1.5mm cable from the joystick panel to the junction box.
Supply cable to the junction box.

6 - Operating Instructions

This equipment is designed for use out of doors, in free air. Never place anything on or cover the searchlight when in use as this may present a hazard.

The searchlight can be remotely positioned via the joystick control panel, with the facility for movement up, down, left and right. When in the desired position the joystick should be released so that it returns to its' home position, dead centre.

The beam of the searchlight can be adjusted to give a variety of beam types. Using the yellow remote focus button on the joystick panel, the desired beam can be achieved for any particular application. The beam will move continuously through 'spot' to 'flood'. In order to fix the beam type; simply release the button at the desired position.

The heaters specified on this equipment are self-regulating and will shut off when they reach the dew point temperature.

The searchlight is also fitted with a breather at the rear of the searchlight which ensures a steady airflow to prevent any vacuum forming within the barrel.

This product should not be used for any purpose other than for which it was designed. Any modifications to the product should not be undertaken without consulting the manufacturer.

Setting to Work

Safe service in use necessitates the strict observance of the following precautions.

- Any article fabricated from quartz or glass is inherently fragile and care should therefore be taken, at all times, when handling lamps.
- Eye protection must be worn when handling lamps that have been removed from their packaging materials. The protective cover should not be removed from the lamp prior to use for safety reasons, as there is a remote possibility of the lamp shattering violently, especially if it is subjected to mechanical shock or vibration.
- Ensure that the power rating of the lamp to be fitted is suitable for the lamphouse and power supply equipment.
- Always isolate the equipment from the supply before inserting a lamp.
- Do not twist or bend the bulb when fitting the lamp as mechanical stresses **MUST** be avoided.
- When inserting or removing a lamp, always hold it securely by its' base in order to prevent breakage between base and bulb.
- The lampholder must not exercise mechanical tensions on the lamp, neither during insertion or operation.
- For safety reasons, the lamp should be replaced once it has reached its' average life, and not later than 1.25 times the stated life. With continuing use, the risk of the lamp exploding increases due to alterations within the quartz.
- Before the protective sleeve is removed, suitable protection must be worn i.e face mask and gloves with wrist protection.
- Never touch the quartz bulb with bare hands, as fingerprints will make the glass cloudy and cause a severe loss of light. This may also cause recrystallisation and thus weaken the bulb material. Should the bulb be inadvertently touched, remove fingerprints with methylated spirit and a clean, soft paper towel. The bulb should then be wiped with distilled water. **NOTE: ALWAYS WEAR MASK AND GLOVES DURING CLEANING.**
- All packaging and the protective sleeve must be retained for re-use.

7- Fault Finding

All fault finding must be conducted by a competent person or qualified Electrical Engineer.

Failure of Lamp to ignite

In the event of the lamp failing to light the following steps should be taken:

- 1) Check that the supply is connected to the input of the Ballast and check all connections as per the wiring diagrams show below. On operation if the lamp does not light, switch off supply and check all fuses.

Any further tests to be carried out with regards to lamp failure must be conducted by a competent electrical engineer and should not be carried out in an explosive atmosphere.

- 1) Before a xenon lamp will ignite, the electrically insulated gas between the electrodes must be ionised. This is done by the ignitor which produces a high frequency voltage. Switching the lamp on activates the ignitor. A cracking or hissing noise should be heard. The ignitor is housed within the rear of the searchlight barrel. If found to be faulty a new ignitor must be fitted.

Failure of Remote Focus

Causes:

- 1) Power not supplied.
- 2) Faulty connections.
- 3) Failed motor.

Remedy:

- 1) Check voltage at supply. If no supply present fault is at customer supply. If power is present, see remedy 2.
- 2) Check all wiring connections on motor and terminal rail, in accordance with the wiring diagram. If found to be correct, see remedy 3.
- 3) Remove focus motor and apply 24v DC directly across terminals. If motor does not rotate the unit has failed. A new focus motor should be fitted to the lampholder assembly.

8 - Maintenance and Servicing

In order to prolong the service life and performance of your searchlight, the following maintenance guidelines are recommended:

- Maintenance checks should be conducted before every voyage or at least every three months.
- Before checking, disconnect the equipment from the supply.
- Visually inspect the condition of the equipment.
- Any major or minor structural damage should be rectified immediately in order to reduce sympathetic wear.
- After inspection it may be necessary to clean the inside of the searchlight. The following procedure should be adhered to:
 - Remove the front bezel.
 - Clean the front glass inside and out using a proprietary glass cleaner.
 - Clean the reflector if required.
- It is advisable to check all seals and gaskets for signs of degradation. Renew if necessary.
- Upon completing all maintenance requirements, the searchlight should be tested for full working order (approximately 20 minutes).

If in any doubt as to the correct servicing procedures to adopt, please contact your distributor/agent or the manufacturer who will be able to advise the best course of action for your product.

Notes for Lamp Fitting/Removal for LX230RC 100w remote focus HID Xenon

Ensure all screws are retained carefully in a safe position

- Remove lamp from packaging, ensuring protective case is still in place.
- Remove front bezel from searchlight by unfastening the three clips.
- Remove the four M3 x 8 button head screws and washers that attach the reflector to the side tilt brackets.
- Remove the reflector assembly.
- Un-clip the lamp leads and focus motor leads.
- Remove the three M3 x 10 button head screws that retain the front lamp plate & the lamp in its holder.
- Once the front 2 plates have been removed the lamp can now be removed by freeing one lead at a time through the centre bore in the lamp holder boss & lamp holder plate.
- Remove new lamp from protective packaging.
- Replace the lamp by reversing the above procedure.

9 – General Assembly and Wiring Diagrams

Drawing Number	Description
A7205	A7205 LX230RC 100w General Assembly (24v) A7206 LX230RC 100w General Assembly (220v) A7207 LX230RC 100w General Assembly (115v)
C28163	Wiring Diagram 24v
C28161	Wiring Diagram 240v
C28162	Wiring Diagram 110v
C22431	Control Panel
C26221	HV Transformer Junction Box (110v/240v Only)
C26225	Junction Box Assembly

DATE 16/05/2019	MODIFICATION DETAILS AS FIRST DRAWN	RES No	DATE 16/05/2019
1		1	

STANDARD PRACTICE Debur all cut/machined edges Break corners R0.25(Min) U.O.S.	©2019 A1 CONT ON SHEET
--	------------------------



PART No./REV No)
C28163 1

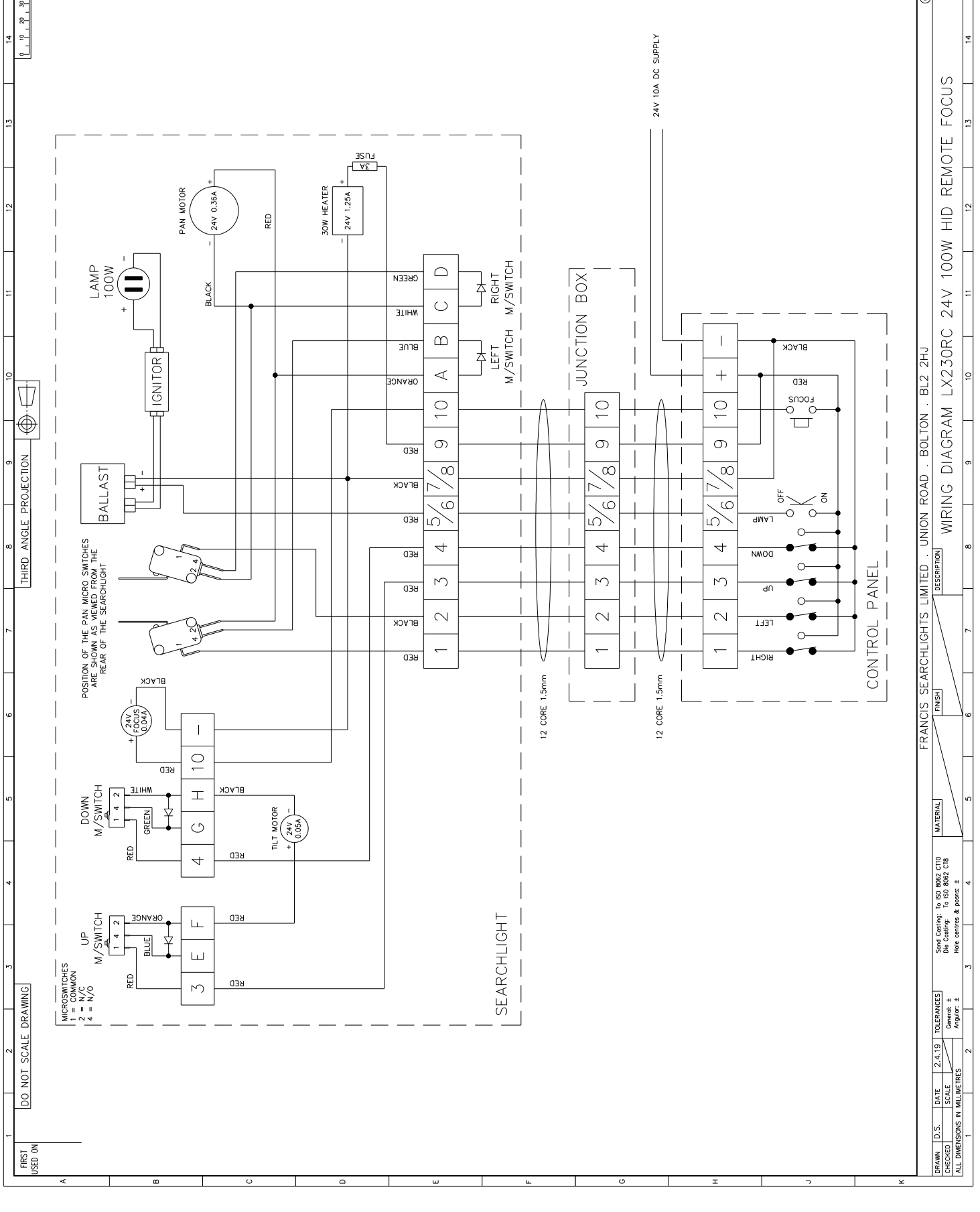

FRANCIS SEARCHLIGHTS LIMITED . UNION ROAD . BOLTON . BL2 2HU	DESCRIPTION	FINISH	MATERIAL	SCALE	TOLERANCES	DATE	DRAWN
WIRING DIAGRAM LX230RC 24V 100W HID REMOTE FOCUS				2:4:1B	±0.10mm	16/05/2019	

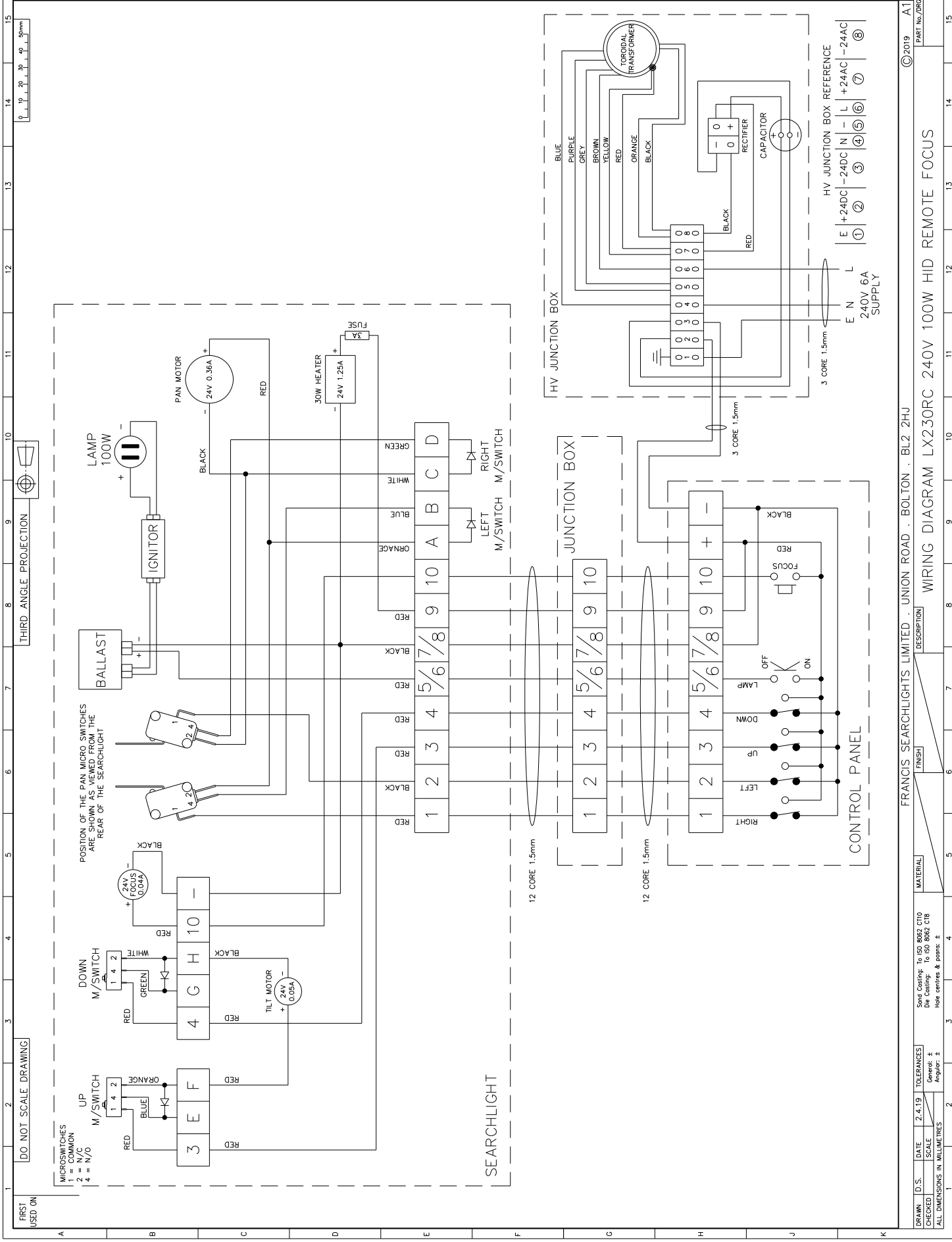

16	DATE & REVISIONS	16
15	MODIFICATION DETAILS	15
14	AS FIRST DRAWN	14
13		13
12		12
11		11
10		10
9		9
8		8
7		7
6		6
5		5
4		4
3		3
2		2
1		1

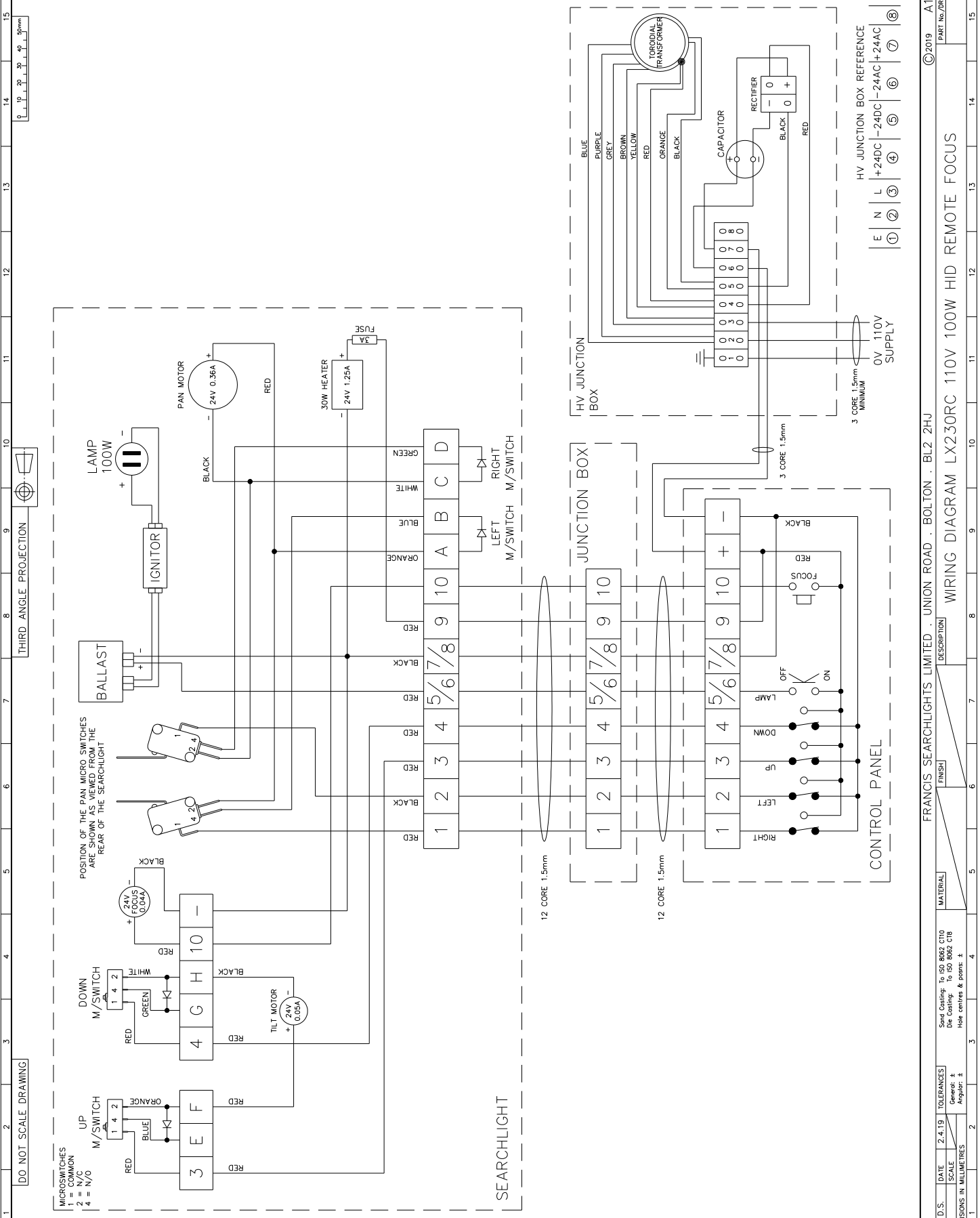

16	STANDARD PRACTICE	16
15	Debur all cut/machined edges	15
14	Break corners R0.25(Max) U.O.S.	14
13		13
12		12
11		11
10		10
9		9
8		8
7		7
6		6
5		5
4		4
3		3
2		2
1		1

©2019 A1 CONT ON SHEET

PART No./REV No.

C28162 1

FRANCIS SEARCHLIGHTS LIMITED · UNION ROAD · BOLTON · BL2 2JH

DESCRIPTION

FINISH

MATERIAL

Scale: To ISO 882 C10
 Die Casting: To ISO 8802 C18
 Hole centres & points: ±
 Angles: ±

TOLERANCES

DATE 2.4.19

DRAWN

CHECKED

ALL DIMENSIONS IN MILLIMETRES

WIRING DIAGRAM LX230RC 110V 100W HID REMOTE FOCUS

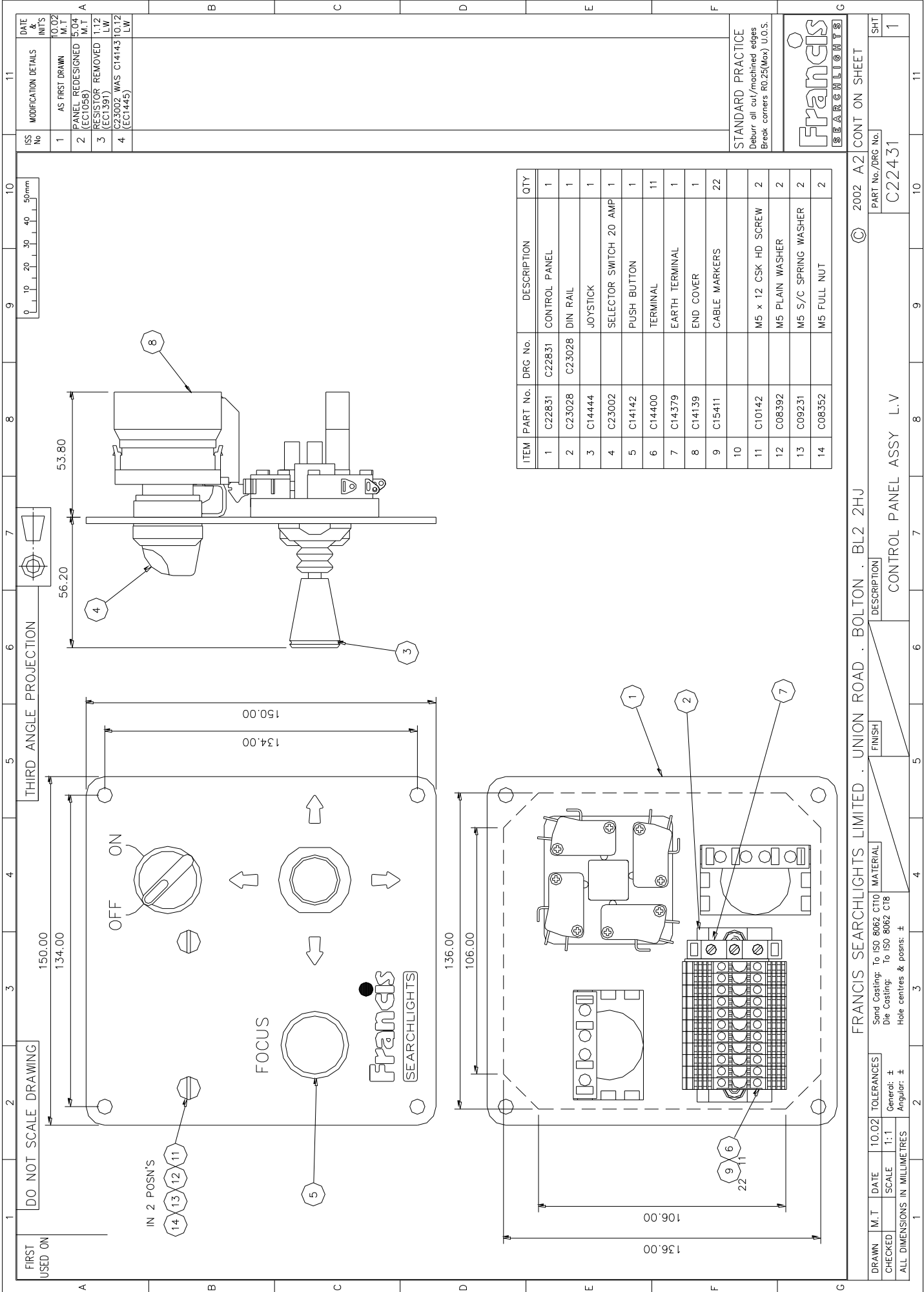

ITEM	PART No.	DRG No.	DESCRIPTION	QTY
1	C2831	C2831	CONTROL PANEL	1
2	C23028	C23028	DIN RAIL	1
3	C14444		JOYSTICK	1
4	C23002		SELECTOR SWITCH 20 AMP	1
5	C14142		PUSH BUTTON	1
6	C14400		TERMINAL	11
7	C14379		EARTH TERMINAL	1
8	C14139		END COVER	1
9	C15411		CABLE MARKERS	22
10				
11	C10142		M5 x 12 CSK HD SCREW	2
12	C08392		M5 PLAIN WASHER	2
13	C09231		M5 S/C SPRING WASHER	2
14	C08352		M5 FULL NUT	2

STANDARD PRACTICE
Deburr oil cut/machined edges
Break corners R0.25(Max) U.O.S.



DATE	10.02	11																																																																						
M.T	M.T																																																																							
MODIFICATION DETAILS	AS FIRST DRAWN																																																																							
ISS No	1																																																																							
	PANEL REDESIGNED (EC1058)	5.04																																																																						
	RESISTOR REMOVED (EC1391)	1.12																																																																						
	C23002 WAS C14143	10.12																																																																						
	(EC1445)	LW																																																																						
<table border="1"> <tr> <td>DRAWN</td> <td>M.T</td> <td>DATE</td> <td>10.02</td> <td>TOLERANCES</td> </tr> <tr> <td>CHECKED</td> <td></td> <td>SCALE</td> <td>1:1</td> <td>General: ±</td> </tr> <tr> <td colspan="5">ALL DIMENSIONS IN MILLIMETRES</td> </tr> <tr> <td colspan="5">Hole centres & posns: ±</td> </tr> <tr> <td colspan="5">Die Casting: To ISO 8062 CT8</td> </tr> <tr> <td colspan="5">Sand Casting: To ISO 8062 CT10</td> </tr> <tr> <td colspan="5">MATERIAL</td> </tr> <tr> <td colspan="5">FINISH</td> </tr> <tr> <td colspan="5">DESCRIPTION</td> </tr> <tr> <td colspan="5">CONTROL PANEL ASSY L.V</td> </tr> <tr> <td colspan="5">PART No./DRG No.</td> </tr> <tr> <td colspan="5">C22431</td> </tr> <tr> <td colspan="5">SHT</td> </tr> <tr> <td colspan="5">1</td> </tr> </table>			DRAWN	M.T	DATE	10.02	TOLERANCES	CHECKED		SCALE	1:1	General: ±	ALL DIMENSIONS IN MILLIMETRES					Hole centres & posns: ±					Die Casting: To ISO 8062 CT8					Sand Casting: To ISO 8062 CT10					MATERIAL					FINISH					DESCRIPTION					CONTROL PANEL ASSY L.V					PART No./DRG No.					C22431					SHT					1				
DRAWN	M.T	DATE	10.02	TOLERANCES																																																																				
CHECKED		SCALE	1:1	General: ±																																																																				
ALL DIMENSIONS IN MILLIMETRES																																																																								
Hole centres & posns: ±																																																																								
Die Casting: To ISO 8062 CT8																																																																								
Sand Casting: To ISO 8062 CT10																																																																								
MATERIAL																																																																								
FINISH																																																																								
DESCRIPTION																																																																								
CONTROL PANEL ASSY L.V																																																																								
PART No./DRG No.																																																																								
C22431																																																																								
SHT																																																																								
1																																																																								
FRANCIS SEARCHLIGHTS LIMITED · UNION ROAD · BOLTON · BL2 2HJ © 2002 A2 CONT ON SHEET																																																																								

FIRST USED ON
A6091

DO NOT SCALE DRAWING

FIG 1

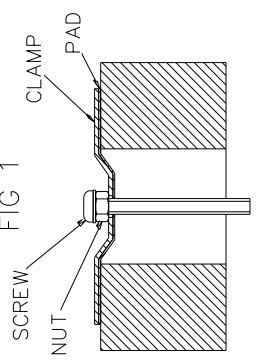

BOX DIM'N 180 x 180 x 130

1
3
4 SEE NOTE 1

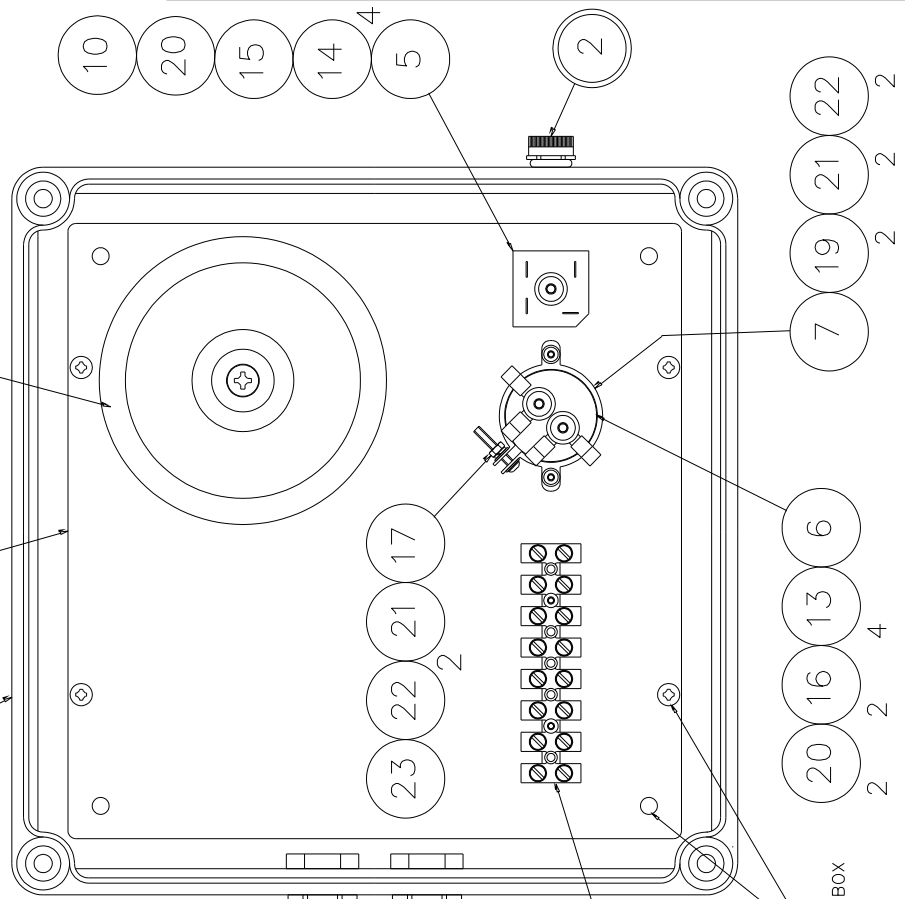

OPTIONAL FIXING POSITIONS
DEPENDANT ON SCREWS SUPPLIED WITH BOX

C26221 240V JUNCTION BOX ASSEMBLY
C28516 110V JUNCTION BOX ASSEMBLY

NOTE

- 1.. USE SCREW & FIXINGS PROVIDED
SCREW NUT FULLY ONTO SCREW
SO SCREW DOES NOT PROTRUDE
THROUGH CHASSIS PLATE (FIG 1)
- 2.. ITEMS 11 & 12 NOT SHOWN
POSITION CENTRAL ON LID
- 3.. ITEMS 24, 25 & 26 NOT SHOWN

ITEM	PART No.	DRG No.	DESCRIPTION	240V 110V	QTY	QTY
1	C26219	C26218	CHASSIS PLATE ASSY		1	1
2	C22268		BREATHER ASSY		1	1
3	C26217	C26217	ENCLOSURE		1	1
4	C24813		TRANSFORMER		1	1
5	C24072		RECTIFIER		1	1
6	C24823		CAPACITOR		1	1
7	C25946		CAPACITOR CLIP		1	1
8	C10158		GLAND		2	2
9	C15133		TERMINAL STRIP 8 WAY		1	1
10	C14232		HEATSINK COMPOUND	A/R	A/R	A/R
11	C21464		LABEL DANGER 230V		1	1
11	C22078		LABEL DANGER 110V		1	1
12	C22036		LABEL ISOLATE SUPPLY		1	1
13	C14695		M5 RED RING TAG		4	4
14	C15828		RED SHROUDED CRIMP		4	4
15	C10620		M5 x 16 BUTTON HD SCREW		1	1
16	C10206		M5 x 12 BUTTON HD SCREW		2	2
17	C10129		M3 x 20 BUTTON HD SCREW		1	1
18	C10203		M3 x 16 BUTTON HD SCREW		2	2
19	C10131		M3 x 10 BUTTON HD SCREW		2	2
20	C08392		M5 PLAIN WASHER		3	3
21	C08028		M3 PLAIN WASHER		4	4
22	C10747		M3 S/C SPRING WASHER		3	3
23	C05298		M3 FULL NUT		1	1
24	C13872		CABLE 1.5mm RED	A/R	A/R	A/R
25	C13873		CABLE 1.5mm BLACK	A/R	A/R	A/R
26	C15112		CABLE 1.5mm G/Y	A/R	A/R	A/R

REV	NO	MODIFICATION DETAILS	DATE	BY
1		AS FIRST DIMM	21.3	LW
2		FRASSIS PLATE MOVED (E61737)	12.18	LIT

STANDARD PRACTICE
Refer all cut/measure edges
Break corners R0.25(Noc) U.O.S.



©2013 A1 CONT ON SHEET
PART No./DRG No.
C26221 1

FRANCIS SEARCHLIGHTS LIMITED · UNION ROAD · BOLTON · BL2 2HU
HV JUNCTION BOX ASSEMBLY (LX230 HV)

DRAWN	LW	DATE	21.3	TOLERANCES
CHECKED	LW <td>SCALE</td> <td>1:1 <td>General: ± Angular: ±</td> </td>	SCALE	1:1 <td>General: ± Angular: ±</td>	General: ± Angular: ±
ALL DIMENSIONS IN MILLIMETRES				

FINISH
MATERIAL
Sand Coating: to ISO 8662 C10
Die Coating: to ISO 8662 C1B
Hole centres & posess: ±

FIRST
USED ON
A6098
A6091
A6091
LX230RC
A6103

DO NOT SCALE DRAWING

THIRD ANGLE PROJ



ISS No	MODIFICATION DETAILS	DATE & INITS
1	AS FIRST DRAWN	2.13 LW

VIEW WITH LID REMOVED

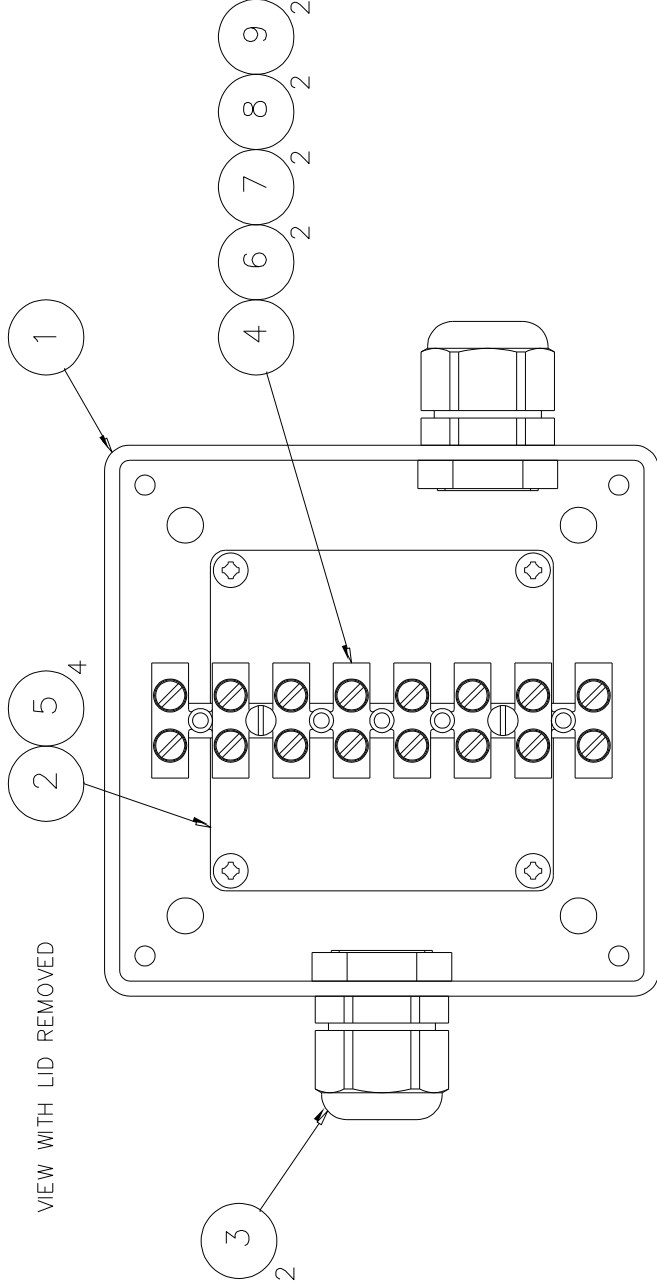

STANDARD PRACTICE
Deburr all cut/machined edges
Break corners R0.25(Max) U.O.S.
TOLERANCES U.O.S: -
General: ±0.25
Angular: ±
Hole centres & posns: ±0.125
Sand Casting: To ISO 8062 CT10
Die Casting: To ISO 8062 CT8

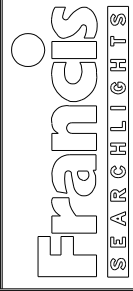

ITEM	PART No.	DRG No.	DESCRIPTION	QTY				
1	C26224	C26224	ENCLOSURE	1	5	C23598	SCREW $\phi 4 \times 8$ PAN POLYMATE	4
2	C26223	C26223	CHASSIS PLATE	1	6	C10129	SCREW M3 x 20 BUTTON HD	2
3	C12415		M20 CABLE GLAND	2	7	C08028	WASHER M3 PLAIN	2
4	C15133		TERMINAL BLOCK (8WAY)	1	8	C10747	WASHER M3 SPRING	2
					9	C05298	NUT M3 FULL	2

FRANCIS SEARCHLIGHTS LIMITED, UNION ROAD, BOLTON, BL2 2HJ

©2013 A3 CONT ON SHEET

DRAWN	LW	DATE	2.13	MATERIAL		FINISH		DESCRIPTION	JUNCTION BOX ASSY (LX230RC 12v)	PART No./DRG No.	C26225	SHT	1
CHECKED		SCALE	1:1	ALL DIMENSIONS IN MILLIMETRES									

10 – Spare Parts List

The following spare parts can be ordered directly from the manufacturer:

Part Number	Description
Searchlight Spares	
D25858	100w Xenon Lamp
C25857-01	100w Ballast & Ignitor Unit
C08865-00	Front glass
C12888-00	Front Glass Infra-Red (Optional)
C21141-00	Front glass gasket
C22268-01	Breather Assembly
C25988-00	Reflector
C16410-00	Focus Motor 24v
C28025-01	Tilt Motor Assembly
C26119-00	Tilt Timing Belt
C27103-01	Pan Motor Assembly
C21211-00	Pan Motor Gear
C10168-00	Base 'O' ring
C26103-00	Bearing Housing Gasket
C21567-00	Searchlight Heater
C24118-00	Fuse
C24021-00	Fuse Holder
C24813-00	Transformer (Model A7206 & A7207 HV Only)
C24072-00	Rectifier (Model A7206 & A7207 HV Only)
C24823-00	Capacitor (Model A7206 & A7207 HV Only)
C28022-00	Micro Switches (Tilt)
C22382-00	Micro Switches (Pan)
Joystick Spares	
C23002-00	On / Off Switch
C14142-00	Focus Push Button
C14444-00	Joystick

In order to prolong the life and performance of your product, we recommend that you only specify Francis Searchlights spare parts. This will ensure that any warranties on your equipment will not be invalidated.

When ordering spare parts please contact the Sales Department at Francis Searchlights Limited. Please quote searchlight model and serial number at all times. This will enable a fast response to your spares' requirements.