



FX560RC Issue 1  
Xenon 3Kw IP67  
Remote Control.



IP67 WATERPROOF



## APPLICATION

The new Francis Bus Premium range of variable speed Remote Controlled Searchlights incorporate the design features required to successfully operate searchlights in the most demanding product operating environments on land and sea. This new model is IP Rated at 67.

Francis Searchlights have developed and improved all remote controlled searchlights across the range still further by adding full variable speed, a new modern and sleek joystick control panel, using membrane and LED technology, offering Bus Control.

The Francis bus (FBUS) is a custom communication protocol based on RS485 two-wire bi directional communication hardware. The system provides a simple bi directional link between searchlights and control panels.

The colour temperature of the Xenon lamp being equal to that of 'sunlight', make this the searchlight ideal for polar regions.

These high power searchlights are well suited to applications where long range and excellent light output are required. For marine applications assisting collision avoidance and man over board situations, and crucially saving lives.

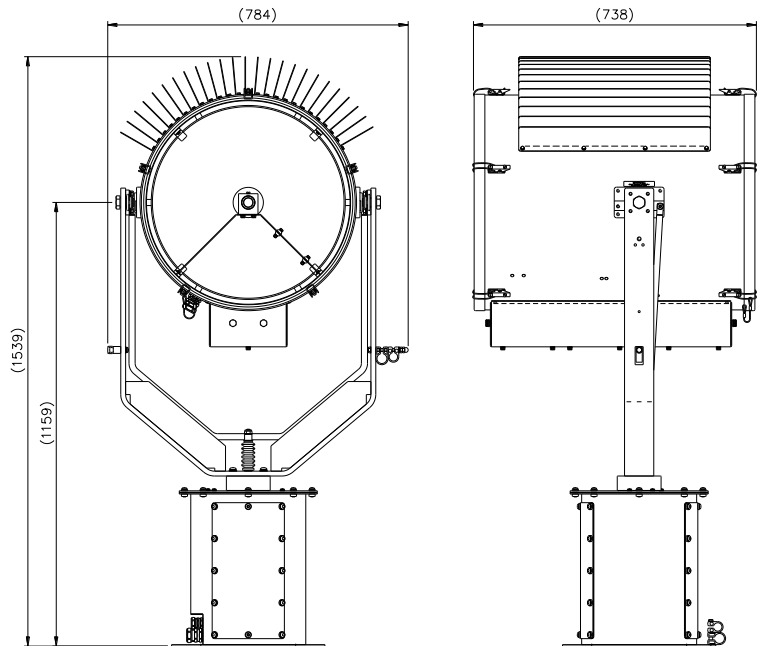

## SPECIFICATION

- Instant re-strike. No "cooling" down time required.
- Toughened super clear Optiwhite front glass.
- Parabolic glass reflector
- Constructed from marine grade materials and fixings
- Powder coated and stove enamel paint finish.
- Pan rotation 385°
- Tilt elevation control +30°, -35°.
- Variable speed LED joystick, with auto home position.
- RS485 connectivity. Dimmable Control Panel.
- Variable Rotation Speed 1 to 23°/sec (Pan)
- Variable Elevation Speed 1 to 8°/sec (Tilt).
- Heater fitted in gearbox & barrel
- Operational temp -52°
- Remote lamp focus, 1.5° spot to 10° flood.
- Sealing - IP67 Gearbox, IP67 Searchlight, PSU IP20
- Weight Searchlight 74kgs, PSU 24Kgs
- High quality Electronic PSU suitable for 50/60 Hz 1ph.

## ALL DIMENSIONS IN MILLIMETRES

Base fixing details:

4 holes 12.5 Ø equi-spaced on a 350mm PCD  
Joystick panel 120 x 120mm (106 x 106mm cutout)

PSU dimensions: 636 x 400 x 217mm

## Part Numbers

Type	Supply	Watts	Part No
FX560RC	230v	3Kw	A7225
3000w Xenon Lamp			D24177

## Optional Controls:

Program Record Function  
Computer Control Software  
Azimuth LED Control Panel  
Master Control Panel (control up to 10 Searchlights)  
Slave Control Panels (with full control)  
Fiber Optic/TCP/IP Connections

VAC	Lamp life	Range @ 1 Lux	PBCP X 1000	Div	Watts
230v	2200hrs	13,251	175,000	1.5°	3000w

Francis Searchlights Limited, Union Road, Bolton, BL2 2HJ, UK

Tel 44 (0) 1204 558960 Fax 44 (0) 1204 558979, Email [sales@francis.co.uk](mailto:sales@francis.co.uk) Website: [www.francis.co.uk](http://www.francis.co.uk)