



APPLICATION

The new Francis Bus Premium range of variable speed Remote Controlled Searchlights incorporate the design features required to successfully operate searchlights in the most demanding product operating environments on land and sea.

Francis Searchlights have developed and improved all remote controlled searchlights across the range still further by adding full variable speed, a new modern and sleek joystick control panel, using membrane and LED technology, offering Bus Control.

The Francis bus (FBUS) is a custom communication protocol based on RS485 two-wire bi directional communication hardware. The system provides a simple bi directional link between searchlights and control panels.

The colour temperature of the Xenon lamp being equal to that of 'sunlight', make this the searchlight ideal for polar regions.

These high power searchlights are well suited to applications where long range and excellent light output are required. For marine applications assisting collision avoidance and man over board situations, and crucially saving lives.

The Francis Xenon searchlight is strong and very well manufactured, and hence is used extensively in security applications, including border control, prisons & watch towers.

SPECIFICATION

- Instant re-strike. No "cooling" down time required.
- Toughened super clear Optiwhite front glass.
- Parabolic glass reflector
- Constructed from marine grade materials and fixings
- Powder coated and stove enamel paint finish.
- Pan rotation 385°
- Tilt elevation control +30°, -35°.
- Variable speed LED joystick, with auto home position.
- RS485 connectivity. Dimmable Control Panel.
- Variable Rotation Speed 1 to 23°/sec (Pan)
- Variable Elevation Speed 1 to 8°/sec (Tilt).
- Heater fitted in gearbox & barrel
- Operational temp -50°
- Remote lamp focus, 1.5° spot to 10° flood.
- High quality PSU suitable for 50/60 Hz 1ph
- Sealing - IP66 Gearbox, IP56 Searchlight, PSU IP56
- Searchlight weight 68kgs,
- PSU weight 24kgs.

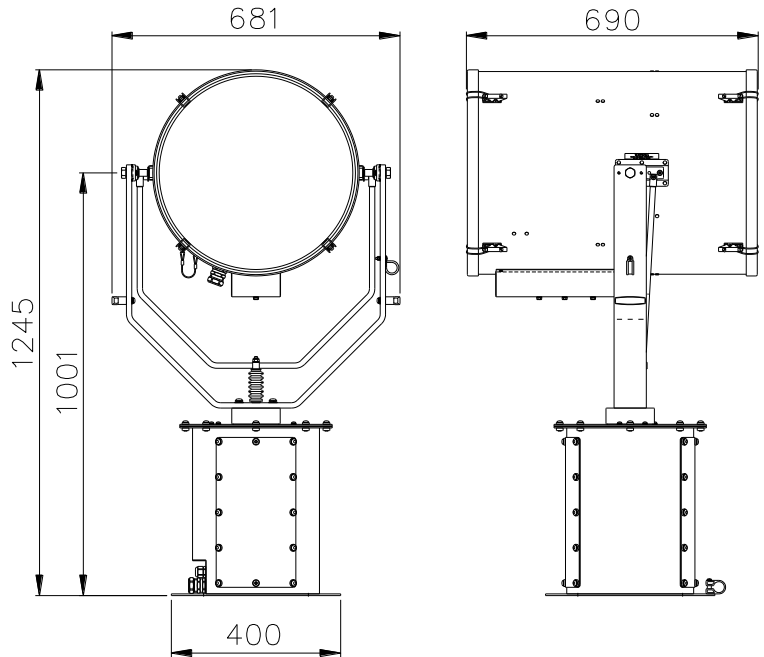

ALL DIMENSIONS IN MILLIMETRES

Base fixing details:

4 holes 12.5 Ø equi-spaced on a 350mm PCD
Joystick panel 120 x 120mm (106 x 106mm cutout)

PSU dimensions: 600 x 438 x 217mm
PSU Fixings: 560 x 340mm

Part Numbers

Type	Supply	Watts	Part No
LX480RC	230v	2kw	A7154
LX480RC	115v	2kw	A7153
2000w Xenon Lamp			D20195

Optional Controls:

- Program Record Function
- Computer Control Software
- Azimuth LED Control Panel
- Master Control Panel (control up to 10 Searchlights)
- Slave Control Panels (with full control)
- Fiber Optic/TCP/IP Connections

VAC	Lamp life	Range @ 1 Lux	PBCP X 1000	Div	Watts
115/230v	3000 hrs	9506m	90,000	1.5°	2000w

For more information contact:

Francis Searchlights Limited
 Union Road, Bolton, BL2 2HJ, UK
 Tel 44 (0) 1204 558960 Fax 44 (0) 1204 558979
 Email sales@francis.co.uk Web site www.francis.co.uk