

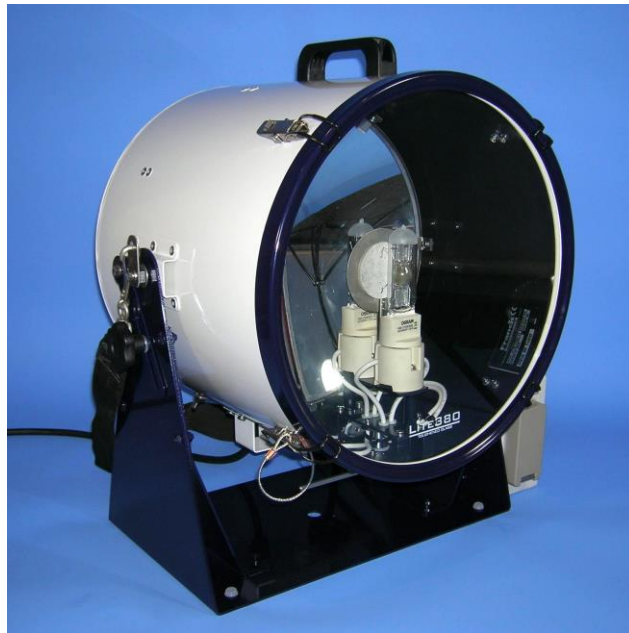

User Instruction & Installation Manual

**LSP380 Portable  
Lightweight Suez 575w**



**Product Reference Number:**

**A2273 – LSP380 115v Portable Light Weight Suez 575w**

**A2274 – LSP380 240v Portable Light Weight Suez 575w**

*Manufacturers details:*

Francis Searchlights Ltd  
Union Road, Bolton  
Lancashire, BL2 2HJ, UK  
Tel: +44 (0) 1204 558960  
Fax: +44 (0) 1204 558979  
<http://www.francis.co.uk>  
E-mail: [sales@francis.co.uk](mailto:sales@francis.co.uk)

*Distributor details:*

Manual Part Number: **C22276**

Issue: 3

# CONTENTS

- 1 - Introduction
- 2 - Safety Precautions
- 3 - Technical Information
- 4 - Unpacking and Installation Instructions
- 5 - Electrical Installation
- 6 - Operating Instructions
- 7 - Fault Finding
- 8 - Maintenance and Servicing
- 9 - Wiring Diagram & General Assembly
- 10 - Spare Parts List

# 1 - Introduction

**It is imperative that this manual is read carefully and understood before installing your equipment. For your future reference please keep this manual in a safe place.**

Thank you for specifying a product from the Francis Searchlights range. All Francis products are designed to give complete customer satisfaction and are manufactured to the highest engineering standards in order to ensure optimum performance and service life.

The Francis LSP range combines features proven over many years service in the most hazardous conditions in both marine and land installations.

In order to prolong the life and performance of your product, we recommend that you only specify Francis Searchlights spare parts. This will also ensure that any warranties on your equipment will not be invalidated. Information on spares ordering and parts is provided in this manual.

Should you ever need to contact Francis Searchlights Ltd. regarding your equipment, please quote the Product Serial Number at all times.

## 2 - Safety Precautions

The following instructions must be adhered to, in order to ensure a safe working environment and the safety of the user.

- Prevent rain, snow, condensation and water droplets from contacting the lamp as this may cause bulb failure and possible shattering;
- Because of the high internal pressure in excess of atmospheric. Whilst the construction is inherently strong, there is a slight risk of the bulb shattering;
- Never look directly into an illuminated searchlight as this may cause severe damage to eyesight. If it is necessary to inspect a lamp whilst in operation, always wear suitable protective goggles;
- Should it be necessary to examine the lamp with the front bezel removed, always use a protective shield and wear goggles to ensure a safe working environment;
- Never attempt to clean a lamp whilst in use;
- Searchlights get hot. Never touch the unit when lit and always allow 15 to 20 minutes for cooling down after turning the searchlight off;
- Never place anything on or cover the searchlight when in use;
- Ensure the lamp has cooled sufficiently before removal;
- If undue force appears necessary to remove the lamp, the equipment should be inspected by a competent person or contact the manufacturer;
- When breaking a lamp for disposal, care must be taken to ensure the glass fragments are safely contained. This operation must be performed out of doors in free air. In all circumstances refer to the lamp manufacturers instructions packed with the lamp;
- Due to the vast range of lamps available it may appear possible that more powerful lamps can be used in the equipment than for which it was designed. Even when the unit will physically accept a higher wattage or voltage lamp, this substitution is not recommended and is dangerous. This action will also void any warranties on the equipment.

**Always refer to the lamp manufacturers technical data when dealing with lamps.**

### 3 - Technical Information

This product has been designed to operate in accordance with the product specification. The LSP380 searchlight has the following features:

- Constructed from marine grade aluminium and stainless steel fixings;
- Parabolic split glass reflector;
- Stove enamel paint finish;
- Vertical movement +5° to -35°;
- Toughened front glass;
- Integral on/off switch;
- Enclosure protection to IP65;
- Weight 15.8Kg which includes Searchlight and power supply;
- Fitted with G22 lamp changeover system, in event of lamp failure;
- Instant lamp re-strike. No cooling down time required.
- Split beam of two 20° sections giving a credible 40° split arc;
- Shoulder carry strap for ease of transportation;

The searchlight also performs to the following optical data:

<b>Volts</b>	<b>Watts</b>	<b>Range @ 1 Lux</b>	<b>P.B.C.P.</b>	<b>Div*</b>	<b>Lamp Life (Hours)</b>	<b>Lamp Cap</b>	<b>Despatch Number</b>
110v	575w	3767M	14,190,201	2.1°	750	G22	D15764
240v	575w	3767M	14,190,201	2.1°	750	G22	D15764

In order that the searchlight operates correctly it is imperative that competent personnel are responsible for the installation, operation and servicing of this equipment. Failure to adhere to this advice may cause premature failure or incorrect operation of the searchlight, which may damage the equipment or cause personal injury.

## 4 - Unpacking and Installation Instructions

The following instructions should be read and fully understood prior to installing the equipment to ensure that the correct procedures are followed, and all safety precautions are observed.

**Note: If the equipment has been in storage for a considerable amount of time, it is advisable to conduct a routine maintenance check on all parts before installation.**

### **Safety Precautions**

This equipment should not be connected to an electrical supply before being installed. Installation procedures should be adhered to in order to ensure a safe working environment and reduce the risk of damage or personal injury.

### **Preparing the Mounting Position**

Mark out and drill the fixing holes through the deck, it may be necessary to use a suitable sealant such as silicone on any uneven surfaces, in order to ensure a weatherproofed joint.

## 5 - Electrical Installation

For safety purposes, only competent personnel should perform the electrical installation. All equipment should be installed to current Electrical Regulations and Standards.

In order to obtain the maximum light output from the searchlight, it is essential that the full operating voltage of the lamp fitted be applied to the lampholder contacts.

### Method of Electrical Connection

- 1) Disconnect the supply before working on the electrical system;
- 2) The searchlight must be connected to a fused electrical supply, using suitably sized cable;
- 3) If the searchlight is located a considerable distance from the supply, provision must be made in the cable size in order to overcome the voltage drop. The following table should be used for indication purposes only:

Searchlight	110v 575w	240v 575w
Cable Size (mm <sup>2</sup> )	Distance Max	Distance Max
1.5	27 MTRS	129 MTRS
2.5	44 MTRS	210 MTRS
4.0	70 MTRS	333 MTRS
6.0	109 MTRS	520 MTRS
10.0	183 MTRS	871 MTRS

- 4) Whenever possible cable terminations should be made below deck and with approved terminal devices;
- 5) If a spare auxiliary fuse or circuit breaker is not available, one of the correct type and rating should be fitted and connected to a positive supply. It is advisable to locate a bus bar or main connection and avoid any direct connection to the supply;
- 6) For 110/220v AC products, the following colour coding system should be used for the customer supply cable:

Brown - Live  
Blue - Negative  
Green/Yellow - Earth

**Note: This equipment must be earthed.**

## 6 - Operating Instructions

This equipment is designed for use out of doors, in free air. Never place anything on, or cover, the searchlight when in use as this may present a hazard.

The beam of the searchlight can be adjusted to give a 40° split, simply release the external lock wheel and adjust the lever to achieve the desired beam split required.

In event of lamp failure, the changeover mechanism can be activated by rotating the lever 180°, which then switches power to the second lamp. The second lamp may take a few seconds to achieve full brightness.

**This product should not be used for any purpose other than for which it was designed. Any modifications to the product should not be undertaken without consulting the manufacturer.**

### Setting to Work

Safe service in use necessitates the strict observance of the following precautions.

- Any article fabricated from quartz or glass is inherently fragile and care should therefore be taken, at all times, when handling lamps;
- Eye protection must be worn when handling lamps that have been removed from their packaging materials. The protective jacket should not be removed from the lamp for safety reasons, as there is a remote possibility of the lamp shattering violently, especially if it is subjected to mechanical shock or vibration;
- Always isolate the equipment from the supply before inserting a lamp;
- Before inserting the lamp ensure that all contacts are clean. Contacts must be renewed at the slightest sign of corrosion. Sanding or filing down corroded areas is not recommended as this will only make the conducting surface between the pin and lampholder smaller, thus causing the lamp to overheat;
- Do not twist or bend the fused quartz bulb when fitting the lamp as mechanical stresses MUST be avoided;
- The lamp must be capable of unimpeded expansion when it warms up to operating temperature. Mechanical forces must not be applied to the fused quartz bulb;
- Before the protective jacket is removed, suitable protection must be worn i.e face mask and gloves with wrist protection;
- Never touch the quartz bulb with bare hands, as fingerprints will make the glass cloudy and cause a severe loss of light. This may also cause recrystallisation and thus weaken the bulb material. Should the bulb be inadvertently touched, remove fingerprints with methylated spirit and a clean, soft paper towel. The bulb should then be wiped with distilled water. NOTE: ALWAYS WEAR MASK AND GLOVES DURING CLEANING);

**In all circumstances the lamp manufacturers data should be referred to when dealing with lamps.**



*When fitting the lamp:*

- Always isolate the equipment from the supply when inserting a lamp;
- Ensure the circuit is suitably fused;
- Ensure the lamp is of the correct power rating and type;
- Check lampholder is in good condition. If the contacts show any sign of corrosion, replace the lampholder;
- Check the lampholder is in a good dry condition. Never allow water to collect in the lamp fitting or come into contact with the lamp.

*To fit the lamp:*

- Loosen all the latches from the front of the searchlight by pressing down the safety catch and releasing the clip, remove the bezel and glass and store in a safe place;
- Cut open one end of the protective sleeve surrounding the lamp;
- Using the sleeve to prevent the fingers coming into contact with the lamp, position the two pins above the holes in the lampholder;
- Gently push the lamp into the lampholder and remove the protective sleeve;

## **Testing**

Upon correct installation and connection to an electrical supply, the equipment can be tested in order to ensure its' correct performance. A competent person with some knowledge of electrical equipment must carry out this work.

Equipment required:     Multimeter with leads  
                                  Ammeter

Using the equation  $P=VI$ , the approximate power output of the equipment can be calculated in the following way:

- Using the multimeter, take a voltage reading;
- Using the ammeter, take an amp reading from the live cable to the lamp;
- Multiply these figures together to give an approximate wattage (Power output).

For example:

Using a 240v 1000w Tungsten halogen lamp:  
Voltage reading = 240v; Amps reading = 4 amps

Therefore, Wattage =  $240 \times 4 = 960$  watts

## 7- Fault Finding

All fault finding must be conducted by a competent person or qualified Electrical Engineer.

### **Failure of Lamp to light**

*Causes:*

- 1) Power not supplied;
- 2) Fuse blown;
- 3) Failed lamp

*Remedy:*

- 1) Check voltage at supply. If supply is not present the fault is at the customer supply. If power is present, see remedy 2;
- 2) Check fuse for visual failure. If none noticeable check fuse for continuity using a multimeter. If fuse found to be faulty, replace with new part and test equipment again for correct working order. If found to be working correctly see remedy 3;
- 3) Firstly, check supply at rear bulkhead terminal rail (within searchlight barrel). If supply is present, disconnect unit from power supply before removing the lamp. If the lamp envelope is discoloured, replace the lamp. Replace lamp ensuring all precautions and instructions previously outlined in this manual are adhered to.
- 4) Check that the fans in the power supply box are working correctly, if not check that the supply is present if so, replace fan.
- 5) Check input supply to the power supply unit is correct.
- 6) Check that the switch on the searchlight barrel is working correctly, if not check that the supply is present if so, replace switch.

## 8 - Maintenance and Servicing

In order to prolong the service life and performance of your searchlight, the following maintenance guidelines are recommended:

- Maintenance checks should be conducted before every voyage or at least every three months;
- Before checking, disconnect the equipment from the supply;
- Visually inspect the condition of the equipment;
- Any major or minor structural damage should be rectified immediately in order to reduce sympathetic wear;
- After inspection it may be necessary to clean the inside of the searchlight. The following procedure should be adhered to:
  - Remove the front bezel;
  - Clean the front glass inside and out using a proprietary glass cleaner;
  - Clean the reflector if required;
  - Check the reflector mounting gaskets. If signs of corrosion or damage are evident, replace as necessary;
  - Ensure that the lampholder is free from corrosion or other damage;
  - Check earth point for conductivity;
- It is advisable to check all seals and gaskets for signs of degradation. Renew if necessary;
- Upon completing all maintenance requirements, the searchlight should be tested for full working order (approximately 20 minutes).

**If in any doubt as to the correct servicing procedures to adopt please contact your distributor/agent or the manufacturer who will be able to advise the best course of action for your product.**

## 9 – Wiring diagram & General Assembly

<b>Drawing Number</b>	<b>Description</b>
C22018	Wiring Diagram
A2273	General Assembly

FIRST USED ON

DO NOT SCALE DRAWING  
 NOTE: -  
 CLOSE DIMMER TERMINALS  
 USING LINK WIRE.

USE TERMINAL MARKERS FOR  
 PROXIMITY SWITCH AS SHOWN. (1 & 2)

THIRD ANGLE PROJ

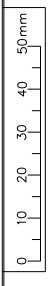

VIEWED FROM THE REAR  
 OS THE SEARCHLIGHT

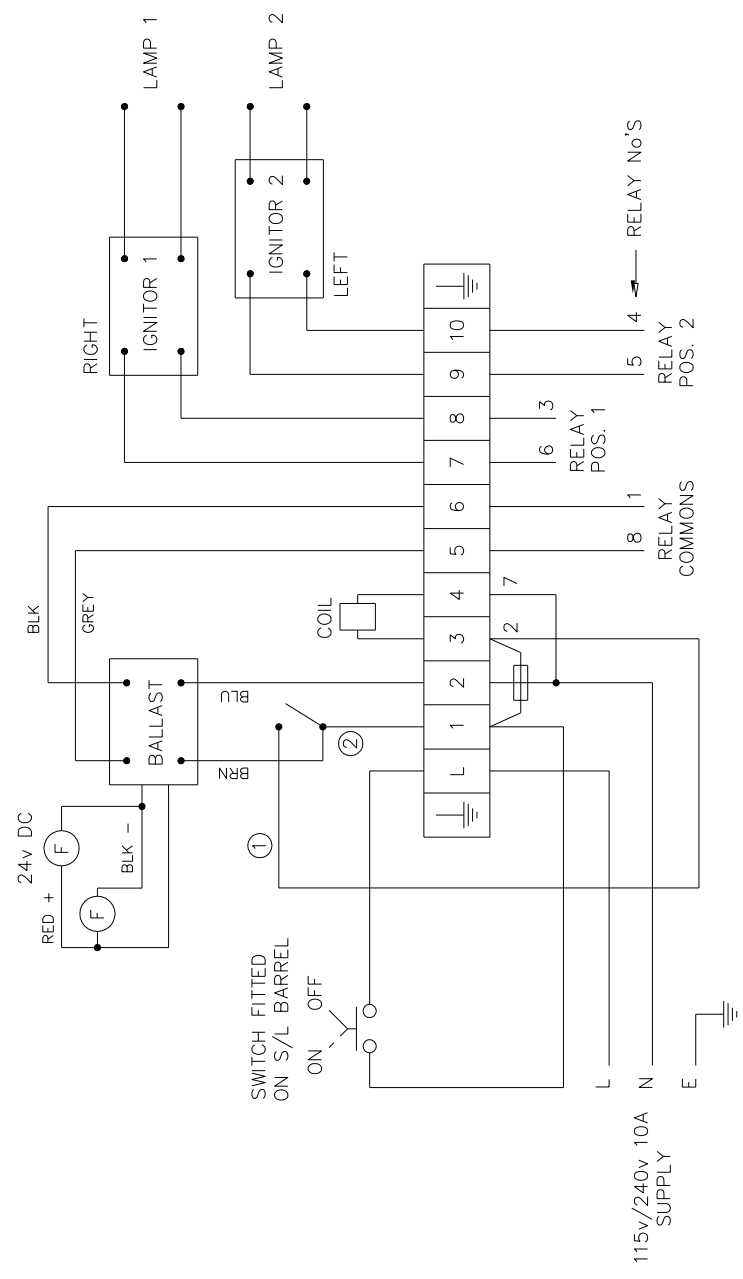

ISS No	MODIFICATION DETAILS	DATE & UNITS
1	AS FIRST DRAWN	1.03 D.S.
2	NOTE ADDED SWITCH TERMINAL No'S ADDED (EC1014)	2.03 D.S.
3	5 CORE CABLE COLOUR CHANGE (EC1084)	12.05 M.T

STANDARD PRACTICE  
 Deburr all cut/machined edges  
 Break corners R0.25(Max) U.O.S.  
 TOLERANCES U.O.S: -  
 General: ±  
 Angular: ±  
 Hole centres & posns: ±  
 Sand Casting: To ISO 8062 CT10  
 Die Casting: To ISO 8062 CT8

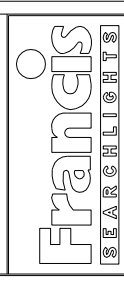

©2001	A3	CONT ON SHEET
PART No./DRG No.	C22018 1	

FRANCIS SEARCHLIGHTS LIMITED, UNION ROAD, BOLTON, BL2 2HU  
 DESCRIPTION  
 WIRING DIAGRAM

DRAWN	D.S.	DATE	19.12.01	MATERIAL	FINISH
CHECKED		SCALE			
ALL DIMENSIONS IN MILLIMETRES					



## 10 - Spare Parts List

The following spare parts can be ordered directly from the manufacturer:

<b>Part Number</b>	<b>Description</b>	<b>Part Number</b>	<b>Description</b>
C22106	PSU Assy.	C11025	Lockwheel Assy.
C20595	Elevation bush	C20596	Elevation washer
C22170	Elevation link	C22103	Shoulder strap
C16893	Grommet	C22268	Ventilation plug assy.
C22198	Lampholder Assy.	C22151	Rear gasket
C22041	Proximity switch	C14239	Handle (Top)
C09880	Switch	C22051	Sealing boot
C20550	Latch	C22056	Ignitor
C22044	Relay base	C22045	Relay 115v
C22046	Relay 240v	C22042	Varistor 115v
C22043	Varistor 240v	C22061	Front glass
C22011	Front glass gasket	C10870	Lampholder
C22040	Magnet	C13980	Reflector
C20827	Reflector pads	C02196	Shutter spring
C05125	Tension spring	C22104	PSU Fan
C22055	PSU	D15764	575w Lamp

In order to prolong the life and performance of your product, we recommend that you only specify Francis Searchlights spare parts. This will ensure that any warranties on your equipment will not be invalidated.

When ordering spare parts please contact the Sales Department at Francis Searchlights Limited. Please quote searchlight model and serial number at all times. This will enable a fast response to your spares' requirements.