



APPLICATION

The Francis Bus Explorer range of variable speed Remote Controlled Searchlights incorporate the design features required to successfully operate searchlights in the most demanding product operating environments on land and sea.

Francis Searchlights have developed and improved all remote controlled searchlights across the range still further by adding full variable speed, a new modern and sleek joystick control panel, using membrane and LED technology, offering Bus Control.

The Francis bus (FBUS) is a custom communication protocol based on RS485 two-wire bi directional communication hardware. The system provides a simple bi directional link between searchlights and control panels.

These units are particularly suitable for use on patrol Craft, custom vessels and is used extensively in security applications, including border control, prisons & watch towers.

The metal halide offers a colour temperature of 6000k similar to daylight, and offers exceptional illumination, especially in polar regions and long range navigation.

SPECIFICATION

- Instant re-strike. No "cooling" down time required.
- Toughened super clear Optiwhite front glass.
- Parabolic glass reflector.
- Constructed from marine grade materials and fixings.
- Powder coated and stove enamel paint finish.
- Pan rotation 365°.
- Tilt elevation control ±35°.
- Variable speed LED joystick, with auto home position.
- RS485 connectivity. Dimmable Control Panel.
- Variable Rotation Speed 1 to 60°/sec (Pan).
- Variable Elevation Speed 1 to 17°/sec (Tilt).
- Heater fitted in gearbox & optional in barrel.
- Operational temp -50°.
- Remote lamp focus, 2.5° spot to 10° flood.
- High quality control gear 50/60 Hz 1ph.
- Sealing - IP67 Gearbox, IP66 Searchlight, PSU IP66.
- Searchlight weight 35kgs, PSU weight 9.5kgs.
- Redesigned gearbox housing, incorporating cable termination, for direct connection.

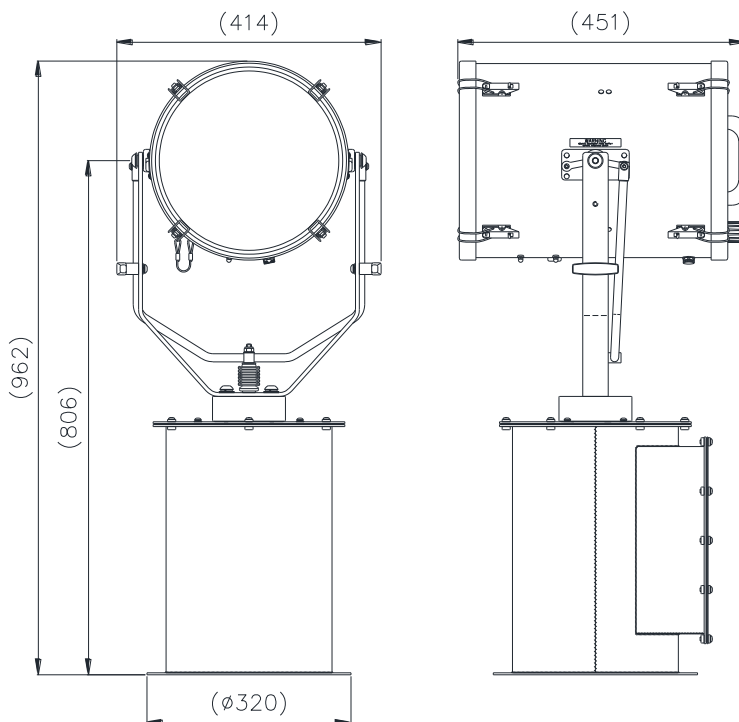

ALL DIMENSIONS IN MILLIMETRES

Base fixing details:

4 holes 12.5 Ø equi-spaced on a 290mm PCD
Joystick panel 120 x 120mm (106 x 106mm cutout)

PSU dimensions: 280 x 190 x 182mm

Part Numbers

Type	Supply	Watts	Part No
FH300RC	230v	575w	A7136
FH300RC	230v	575w	A7136TH
575w G22 Lamp			D15764

Optional extras:

- Computer Control Software
- Azimuth LED Control Panel
- Master Control Panel (control up to 6 Searchlights)
- Slave Control Panels (with full control)
- Fiber Optic/TCP/IP Connections
- Flir Thermal camera

VAC	Lamp life	Range @ 1 Lux	PBCP X 1000	Div	Watts
230v	1000 hrs	3685m	13,600	2.5°	575w