



APPLICATION

The new Francis LED Signalling Searchlight range continues to develop and offers an Efficiently and Environmentally Friendly alternative to traditional lamp sources. Using the highest grade of LED's, this range offers a high power output with low power consumption. In addition, the LED offer a lamp life of 33,000 hours

Francis Searchlights have developed and improved all remote controlled searchlights across the range still further by adding full variable speed, a new modern and sleek joystick control panel, using membrane and LED technology, offering Bus Control.

The FSP300RC Signalling range of searchlights is suited to vessels that require a permanently installed day/ night visual signalling searchlight.

Standard features include remote focus mechanism and combined tubular and V sights.

The well designed shutter mechanism can be locked in the 'open' position, allowing the unit to be used as a searchlight.

The high quality equipment will perform in the most demanding product operating environments on land and sea.

SPECIFICATION

- Toughened super clear Optiwhite front glass.
- High quality shutter mechanism for morse code
- Signalling range minimum of 10 miles / 16 km (daylight)
- Signalling speed of 12 words per minute
- Parabolic glass reflector
- Constructed from marine grade materials and fixings.
- Powder coated and stove enamel paint finish.
- 33,000 lamp life hours.
- Up to 13,900 Lumens.
- Colour Temp options 6500k.
- Pan rotation 365°.
- Tilt elevation control $\pm 35^\circ$.
- Operational temp -50°
- Remote lamp focus fitted as standard.
- Searchlight weight 35Kgs, PSU 3Kgs.
- High quality control gear 50/60 Hz 1ph.
- Sealing - IP66 Gearbox, IP66 Searchlight, PSU IP66.
- Variable speed LED joystick, with auto home position.
- RS485 connectivity. Dimmable Control Panel.
- Variable Rotation Speed 1 to 19°/sec (Pan).
- Variable Elevation Speed 1 to 6°/sec (Tilt).
- Heater fitted in gearbox & optional in barrel.

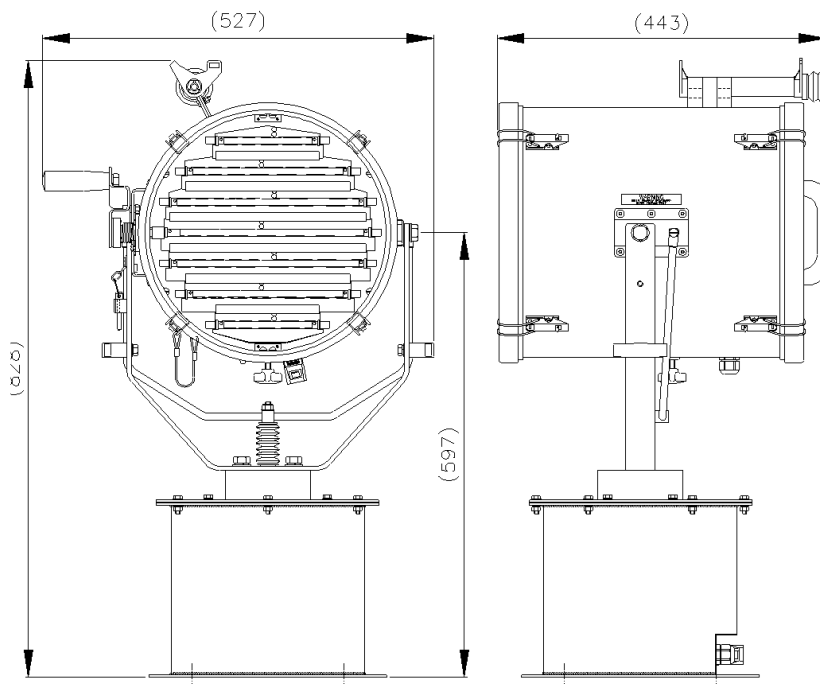

ALL DIMENSIONS IN MILLIMETRES

Base fixing details:

4 holes 12.5 \varnothing equi-spaced on a 290mm PCD

Joystick panel 120 x 120mm (106 x 106mm cutout)

Part Numbers

Type	Supply	Part No
FSP300RC	24v	A7276
FSP300RC	115/230v	A7275
Waterproof Cover		C10233-00
Blue Filter Assy		C23428-00
Green Filter Assy		C23429-00
Red Filter Assy		C21867-00

Optional Controls:

Program Record Function
 Computer Control Software
 Azimuth LED Control Panel
 Master Control Panel (control up to 10 Searchlights)
 Slave Control Panels (with full control)
 Fiber Optic/TCP/IP Connections

VAC	LED life	Range @ 1 Lux	Luminous Flux	Div	Watts
115/230v /24v	33,000 hrs	1089m @ 7°Div	13,900	7-20°	110w