



L300RC Issue 3
250w Laser Searchlight
Remote Control

APPLICATION

The new Francis Laser LED Searchlight range has been developed to offer the most powerful light source available. Using the highest grade of New Technology Laser Diode, this product offers an exceptional light output, low power consumption & in the most compact size possible.

The system uses a series of precision made glass lenses to optimize and collimate the light output, thereby achieving a greater range and illumination. The 250w Laser system gives illumination characteristics in excess of a 2500w Xenon lamp, along with a 12,000 hour life.

As with all Francis products, the construction is robust and of the highest quality. There has been great focus in thermal management to optimise the Laser output and extend the life cycle.

The ultra compact design also benefits from being a fully integrated system, with PSU and drivers being mounted inside the barrel housing.

SPECIFICATION

- Toughened super clear Optiwhite front glass.
- High efficiency , high integrated laser phosphor white module.
- 12,000 lamp life hours
- Precision made glass lenses.
- Constructed from marine grade materials and fixings.
- Powder coated and stove enamel paint finish
- Pan rotation 365°
- Tilt elevation control ±35°.
- Variable speed LED joystick, with auto home position.
- RS485 connectivity, Dimmable Control Panel
- Variable Rotation Speed 1 to 60°/sec (Pan).
- Variable Elevation Speed 1 to 17°/sec (Tilt).
- Heater fitted in gearbox & barrel.
- Operational temp -50°.
- Colour Temp options 6500k
- 16,000 Lumens, plus precision lens magnification.
- Sealing - IP67 Gearbox, IP56 Searchlight.
- Searchlight weight 44kgs.
- Has Signaling capability, ship to ship or ship to shore.
- Remote Focus fitted as standard, giving an impressive range of 1 - 18° beam divergence adjustment. Redesigned gearbox housing, incorporating cable termination, for direct connection.

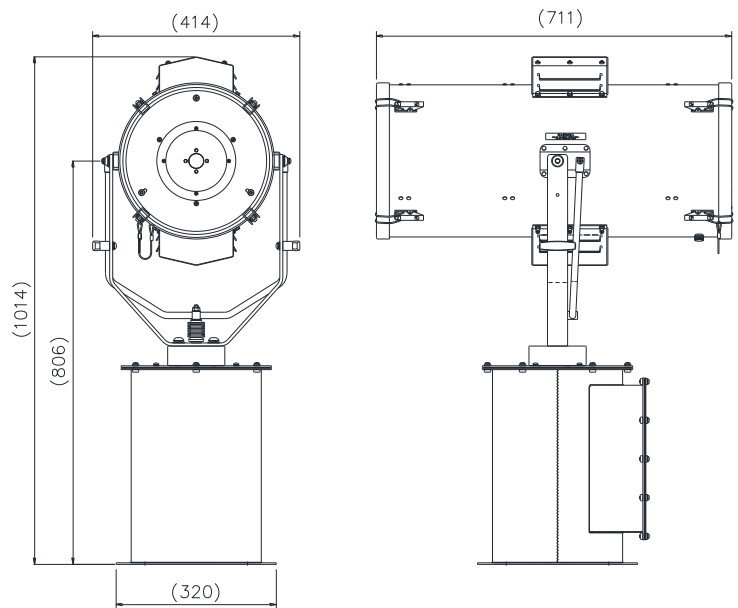

ALL DIMENSIONS IN MILLIMETRES

Base fixing details:
4 holes 12.5 Ø equi-spaced on a 350mm PCD
Joystick panel 120 x 120mm (106 x 106mm cutout)

Part Numbers

Type	Supply	Watts	Part No
L300RC RF	115/230v	250w	A7310

Optional extras:

- Computer Control Software
- Azimuth LED Control Panel
- Master Control Panel (control up to 6 Searchlights)
- Slave Control Panels (with full control)
- Fiber Optic/TCP/IP Connections
- Flir Thermal camera

VAC/DC	Lamp life	Range @ 1 Lux	Luminous Flux	Div	Watts
115/230v	12,000 hrs	8178m	16,000	1-18°	250w

