



APPLICATION

The new Francis LED searchlight range has been developed to offer an Efficiently and Environmentally Friendly alternative to traditional lamp sources.

Using the highest grade of the world class Osram LED, this range offers a high power output with low power consumption. Using a series of precision made glass lenses to optimize and collimate the light output, to achieve a greater range and output. The high power LED Chip has 20,000 hour life.

As with all Francis products, the construction is robust and of the highest quality. To dissipate the heat generated by the high power LED, there has been a great focus on thermal management, and these heat sinks are integrated into the barrel construction.

Francis Searchlights have developed and improved all remote controlled searchlights across the range still further by adding full variable speed, a new modern and sleek joystick control panel, using membrane and LED technology, offering Bus Control, auto home position setting, all at no extra cost, with Optional Controls available on request.

The 234w LED gives illumination characteristics in excess of a 300w Xenon lamp / 3kw Halogen.

SPECIFICATION

- Toughened super clear Optiwhite front glass.
- 20,000 lamp life hours
- Precision made glass lenses.
- Constructed from marine grade materials and fixings.
- Powder coated and stove enamel paint finish
- Pan rotation 365°.
- Tilt elevation control +35°, -40°.
- Variable speed LED joystick, with auto home position.
- RS485 connectivity, Dimmable Control Panel
- Variable Rotation Speed 1 to 19°/sec (Pan).
- Variable Elevation Speed 1 to 6°/sec (Tilt).
- Heater fitted in gearbox & barrel.
- Operational temp -50°.
- Colour Temp options 6000k
- Sealing - IP66 Gearbox, IP56 Searchlight, PSU IP66.
- Searchlight weight 36kgs, PSU weight 4kgs.
- Fixed focus options giving 4° degree Spot(SP), 6° Mid Beam(MD) or 10° Flood(FL).

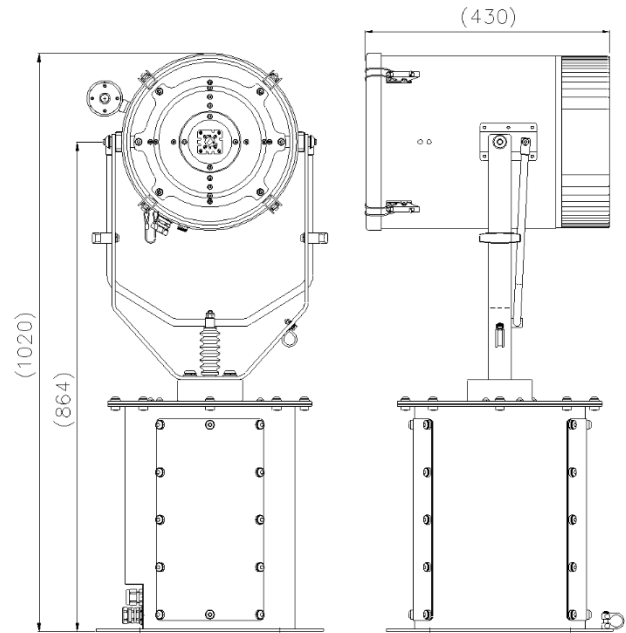

ALL DIMENSIONS IN MILLIMETRES

Base fixing details:

4 holes 12.5 Ø equi-spaced on a 350mm PCD
Joystick panel 120 x 120mm (106 x 106mm cutout)

PSU dimensions: 299 x 302 x 133mm

Part Numbers

Type	Supply	Watts	Part No
L300RC	115/230v	234w	A7178IR, SP, MD, FL

Optional Controls:

- Program Record Function
- Computer Control Software
- Azimuth LED Control Panel
- Master Control Panel (control up to 10 Searchlights)
- Slave Control Panels (with full control)
- Fiber Optic/TCP/IP Connections

Camera Specification:

Fir Thermal camera, image resolution 336 x 256, with 14mm lens, offering exceptional night vision capability, Field of vision 16° horizontal x 13° vertical. Detection = 600m, Recognition = 150m, Identification = 80m

VAC	Lamp life	Range @ 1 Lux	Luminous Flux	Div	Watts
115/230v	20,000 hrs	3177m @ 4°	35,537	4-10°	234w