



APPLICATION

The new Francis Remote Focus LED searchlight range has been developed to offer an Efficiently and Environmentally Friendly alternative to traditional lamp sources.

Using the highest grade of the world class Osram LED, this range offers a high power output with low power consumption. Using a series of precision made glass lenses to optimize and collimate the light output, to achieve a greater range and output.

The high power LED Chip has 20,000 hour life.

As with all Francis products, the construction is robust and of the highest quality. To dissipate the heat generated by the high power LED, there has been a great focus on thermal management, fitting an internal heatsink, cooled by internal fans, maintaining the heatsink at the required temperature, to optimise the chip output.

Francis Searchlights have developed and improved all remote controlled searchlights across the range still further by adding full variable speed, Azimuth LED Position Display, offering Bus Control, auto home position setting, all at no extra cost, with Optional Controls available on request.

The 234w LED gives illumination characteristics in excess of a 300w Xenon lamp / 3kw Halogen.

SPECIFICATION

- Toughened super clear Optiwhite front glass.
- 20,000 lamp life hours
- Precision made glass lenses.
- Constructed from marine grade materials and fixings.
- Powder coated and stove enamel paint finish
- Pan rotation 365° Tilt elevation control +35°, -40°.
- Variable speed LED joystick, with auto home position.
- RS485 connectivity, Dimmable Control Panel
- Variable Rotation Speed 1 to 19°/sec (Pan).
- Variable Elevation Speed 1 to 6°/sec (Tilt).
- Heater fitted in gearbox & barrel.
- Operational temp -50°.
- Colour Temp options 6000k
- Sealing - IP66 Gearbox, IP56 Searchlight, PSU IP66.
- Searchlight weight 34kgs, PSU weight 4kgs.
- Remote Focus fitted as standard, giving an impressive range of 4 - 10° beam divergence adjustment.

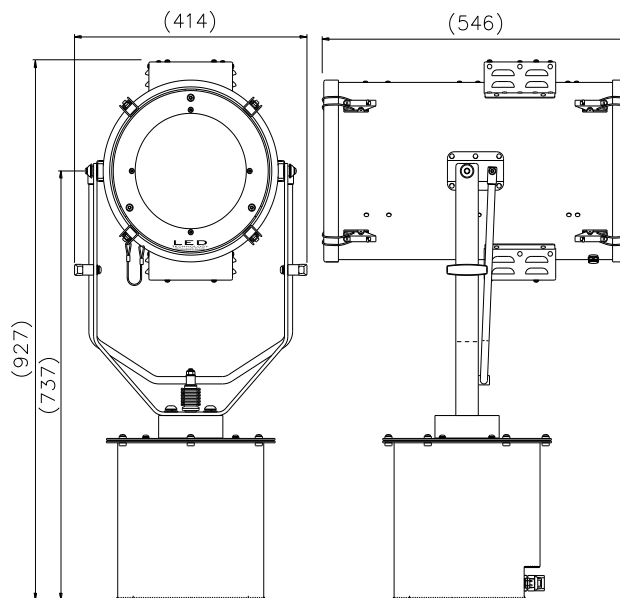

ALL DIMENSIONS IN MILLIMETRES

Base fixing details:

4 holes 12.5 Ø equi-spaced on a 290mm PCD
Joystick panel 1250 x 150mm (106 x 106mm cutout)

PSU dimensions: 299 x 302 x 133mm

Part Numbers

Type	Supply	Watts	Part No
L300RC RF	115/230v	234w	A7221

Optional Controls/Extras:

Program Record Function
Computer Control Software
Azimuth LED Control Panel
Master Control Panel (control up to 10 Searchlights)
Slave Control Panels (with full control)
Fiber Optic/TCP/IP Connections
Flir Thermal camera, image resolution 336 x 256, with 14mm lens, offering exceptional night vision capability, Field of vision 16° horizontal x 13° vertical.
Detection = 600m, Recognition = 150m, Identification = 80m

VAC/DC	Lamp life	Range @ 1 Lux	Luminous Flux	Div	Watts
115/230v 24v	20,000 hrs	3047m	35,537	4-10°	234w