



APPLICATION

The new Francis L380RC 600 LED searchlight range continues to develop and offers an Efficiently and Environmentally Friendly alternative to traditional lamp sources. Using the highest grade of LED, this range offers a high power output with low power consumption.

The 600w LED gives illumination characteristics similar to that of a 6Kw halogen lamp. Using a series of precision made glass lenses to optimize and collimate the light output, to achieve a greater range and output. This model offers a focus adjustment of the beam from 8° spot to 15° flood.

Francis Searchlights have developed and improved all remote controlled searchlights across the range still further by adding full variable speed, a modern and sleek joystick control panel, using membrane and LED technology, offering Bus Control, auto home position setting, with Optional Controls available on request.

The Francis bus (FBUS) is a custom communication protocol based on RS485 two-wire bi directional communication hardware. The system provides a simple bi directional link between searchlights and control panels.

As with all Francis products, the construction is robust and of the highest quality of construction. Utilizing excellent thermal management of the LED chip ensures successful performance and chio life.

SPECIFICATION

- 30,000 lamp life hours.
- Toughened super clear Optiwhite front glass.
- precision made glass lenses
- Constructed from marine grade materials and fixings.
- Powder coated and stove enamel paint finish.
- Pan rotation 385°.
- Tilt elevation control +30°, -35°.
- Variable speed LED joystick, with auto home position.
- RS485 connectivity. Dimmable Control Panel.
- Variable Rotation Speed 1 to 23°/sec (Pan).
- Variable Elevation Speed 1 to 8°/sec (Tilt).
- Heater fitted in gearbox & optional in barrel.
- Operational temp -50° to +50°.
- Up to 58636 Lumens.
- Colour Temp options 7500k.
- High quality control gear 50/60 Hz 1ph.
- Sealing - IP66 Gearbox, IP66 Searchlight, PSU IP66.
- Searchlight weight 65kgs, PSU weight 5Kgs.
- Remote Focus.

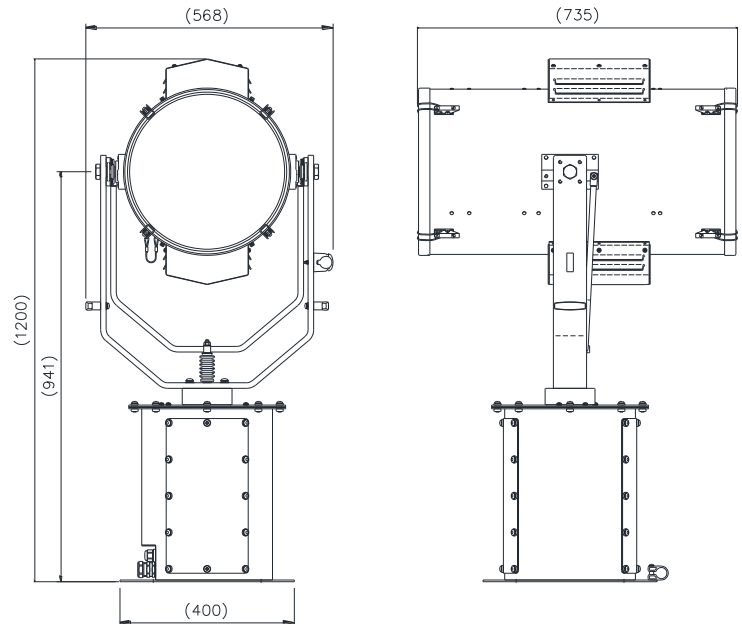

ALL DIMENSIONS IN MILLIMETRES

Base fixing details:

4 holes 12.5 Ø equi-spaced on a 350mm PCD
Joystick panel 120 x 120mm (106 x 106mm cutout)
PSU dimensions: 378 x 278 x 130mm

Part Numbers

Type	Supply	Watts	Part No
L380RC RF	115/230v	600w	A7304

Optional Controls:

Program Record Function
Computer Control Software
Azimuth LED Control Panel
Master Control Panel (control up to 10 Searchlights)
Slave Control Panels (with full control)
Fiber Optic/TCP/IP Connections

VAC	LED life	Range @ 1 Lux	Luminous Flux	Div	Watts
115/230v	30,000 hrs	1957m @ 8°Div	58,636	8-15°	600w