



APPLICATION

The Francis LED searchlight range continues to develop and offers an Efficiently and Environmentally Friendly alternative to traditional lamp sources.

Using the highest grade of LED, this range offers a high power output with low power consumption. The 200w LED gives illumination characteristics similar to that of a 2Kw halogen lamp. This model offers a focus adjustment of the beam from 7° spot to 20° flood.

Francis Searchlights have developed and improved all remote controlled searchlights across the range still further by adding full variable speed, a new modern and sleek joystick control panel, using membrane and LED technology, offering Bus Control, auto home position setting, all at no extra cost, with Optional Controls available on request.

The Francis bus (FBUS) is a custom communication protocol based on RS485 two-wire bi directional communication hardware. The system provides a simple bi directional link between searchlights and control panels.

As with all Francis products, the construction is robust and of the highest quality of construction. Utilizing excellent thermal management of the LED chip ensures successful performance and chip life.

SPECIFICATION

- 33,000 lamp life hours.
- Toughened super clear Optiwhite front glass.
- Parabolic glass reflector
- Constructed from marine grade materials and fixings.
- Powder coated and stove enamel paint finish.
- Pan rotation 385°. Tilt elevation control ±35°.
- Variable speed LED joystick, with auto home position.
- RS485 connectivity. Dimmable Control Panel.
- Variable Rotation Speed 1 to 43°/sec (Pan).
- Variable Elevation Speed 1 to 14°/sec (Tilt).
- Heater fitted in gearbox & optional in barrel.
- Operational temp -50° to +50°.
- Up to 32,000 Lumens.
- Colour Temp options 6500k.
- High quality control gear 50/60 Hz 1ph.
- Sealing - IP67 Gearbox, IP66 Searchlight.
- Searchlight weight 51kgs
- Optional Remote Focus.
- Redesigned gearbox housing, incorporating cable termination, for direct connection to the internal LED Driver.

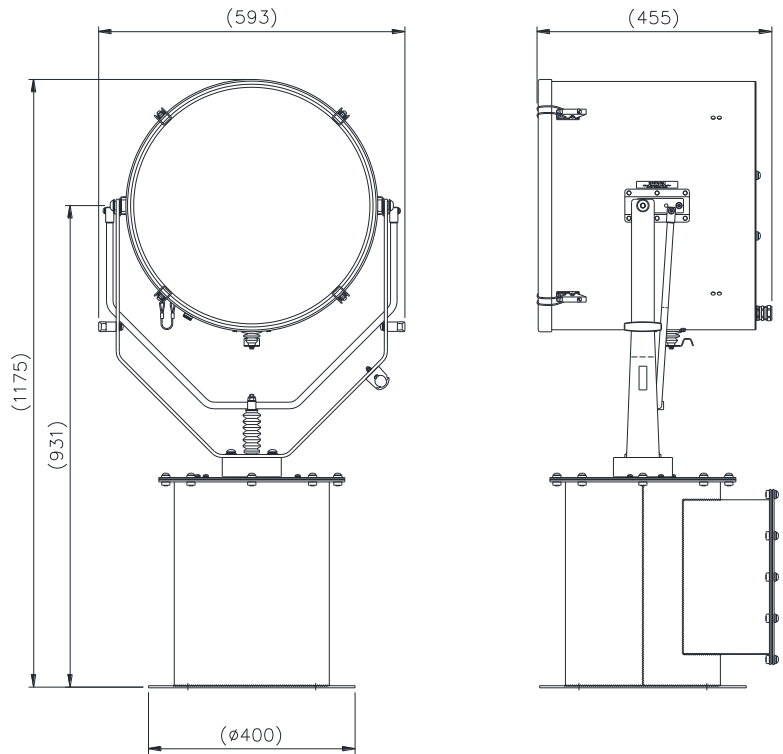

ALL DIMENSIONS IN MILLIMETRES

Base fixing details:
4 holes 12.5 Ø equi-spaced on a 350mm PCD
Joystick panel 120 x 120mm (106 x 106mm cutout)

Part Numbers

Type	Supply	Watts	Part No
L480RC	115/230v	200w	A7222
L480RC RF	115/230v	200w	A7223

Optional Controls:

- Program Record Function
- Computer Control Software
- Azimuth LED Control Panel
- Master Control Panel (control up to 6 Searchlights)
- Slave Control Panels (with full control)
- Fiber Optic/TCP/IP Connections
- Flir Thermal camera

VAC	LED life	Range @ 1 Lux	Luminous Flux	Div	Watts
115/230v	33,000 hrs	1652m @ 7°Div	32,000	7-20°	200w