



LX230 Twin Head



**LX230RC Issue 2
Xenon 2 x 100w Twin
Head Remote Control**

APPLICATION

THE FRANCIS LX230 Remote Control searchlight is part of the high power Xenon range. Having been designed with the precise aim of bringing a low profile, high performing and cost effective solution to the market.

The LX230RC has been carefully developed to withstand the extraordinary conditions while in use in the harshest of environment, such as Patrol Craft, Coast Guard and any application that requires a compact, lightweight and high performer.

Within the Francis LX range of marine searchlights, the LX230, utilizes a 100w xenon lamp, and has been designed to give maximum beam range and candlepower, giving the ability to identify objects and potential dangers from a far greater distance. As an optional extra option, this unit is also available with infra-red night vision ensuring total covert surveillance.

SPECIFICATION

- Instant re-strike. No "cooling" down time required.
- Toughened super clear Optiwhite front glass.
- Parabolic super pure Aluminium reflector.
- Constructed from marine grade materials and fixings
- Powder coated and stove enamel paint finish.
- Pan rotation 365°
- Tilt elevation control $\pm 20^\circ$.
- Pan Rotation Speed 24v = $24^\circ/\text{sec}$, 12v = $12^\circ/\text{sec}$.
- Tilt speed 24v = $4^\circ/\text{sec}$, 12v = $2^\circ/\text{sec}$
- Heater fitted in barrel.
- Economical 3000 hour lamp life.
- Operational temp -50°
- Fixed focus spot.
- Sealing - IP66 Searchlight.
- Searchlight weight 20kgs, High Voltage PSU 4Kgs
- Integral Xenon PSU and lamp fitted as standard
- Optional infrared filter
- Peak Beam Candle Power 3.1 million
- Range 1,761m @ 1 Lux

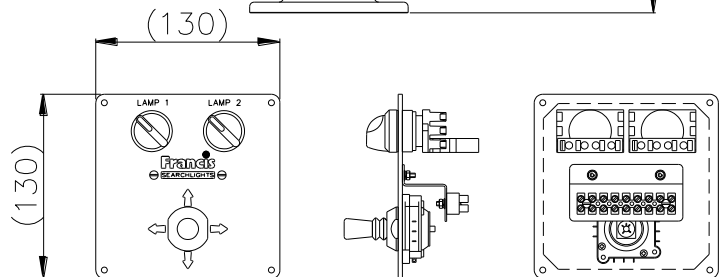
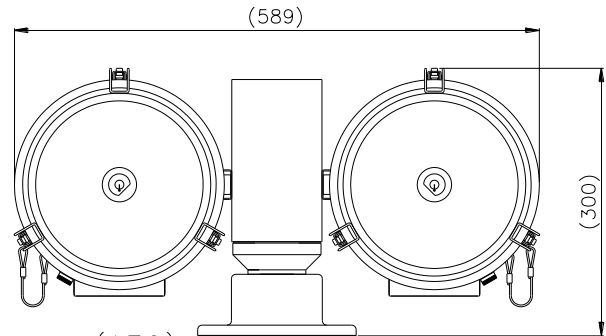
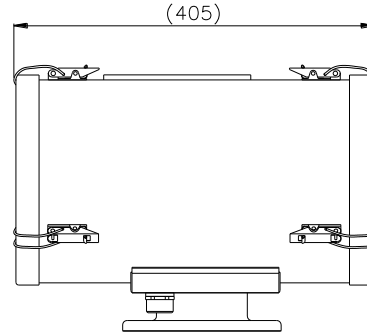

ALL DIMENSIONS IN MILLIMETRES

Base fixing details:
3 holes 11 \varnothing equi-spaced on a 154mm PCD
High Voltage JB: 405 x 278 x 130mm

Part Numbers

| Type | Supply | Watts | Part No |
|-----------------|----------|-------|---------|
| LX230RC | 24v | 100w | A7214 |
| LX230RC | 115/240v | 100w | A7320 |
| 100w Xenon Lamp | | | D25858 |