



APPLICATION

The FRANCIS FX range of XENON searchlights is a Premium product, and incorporate the design features required to successfully operate searchlights in the most demanding product operating environments on land and sea.

The colour temperature of the Xenon lamp being equal to that of 'sunlight', make this the searchlight ideal for polar regions.

These high power searchlights are well suited to applications where long range and excellent light output are required. For marine applications assisting collision avoidance and man over board situations, and crucially saving lives.

The Francis Xenon searchlight is strong and very well manufactured, and hence is used extensively in security applications, including border control, prisons & watch towers.

SPECIFICATION

- Immediate full lamp brilliance from switch on.
- Toughened super clear Optiwhite front glass.
- Parabolic super pure aluminum reflector
- Constructed from marine grade materials and fixings
- Powder coated and stove enamel paint finish.
- Pan rotation 450°
- Deck/Deck Ped Tilt elevation control +45° to -45°.
- Cabin/Cabin Ped Tilt elevation control +20° to -40°
- Heater fitted in barrel
- Operational temp -50°
- High power xenon lamp with 1200 hrs lamp life
- External lamp focus, 1.5° spot to 10° flood.
- Remote Focus fitted as standard.
- Sealing – IP56 Searchlight, PSU IP56
- Searchlight weight Deck 17kgs, Deck Pedestal 25kgs, Cabin 19Kgs, Cabin Pedestal 28Kgs. PSU 9kgs.
- Special B & C dimensions available on request.
- High quality Electronic PSU suitable for 50/60 Hz 1ph
- Light On/Off & Focus Control Box supplied

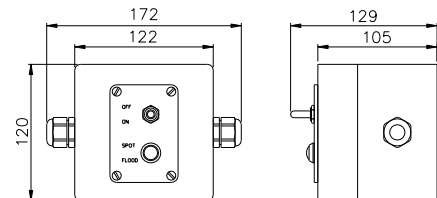
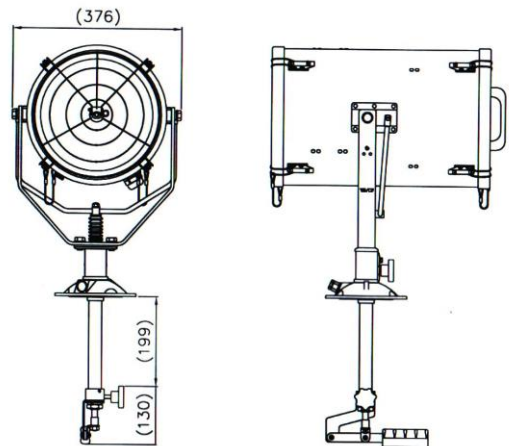
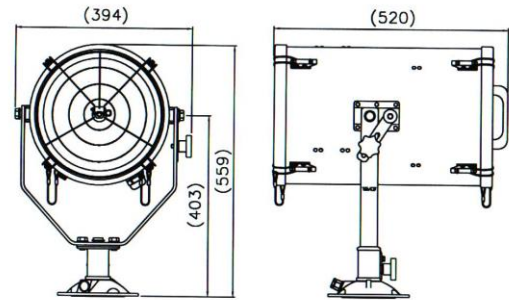

ALL DIMENSIONS IN MILLIMETRES

Base fixing details:
4 holes 11Ø equi-spaced on a 154mm PCD
Cabin center hole Ø 75mm

PSU Dimensions: 405 x 330 x 217mm 110/230v
328 x 280 x 130mm 24v

Part Numbers

Type	Supply	Watts	Part No
LX300D Deck	115/230v	150w	A2418
LX300D Deck	24v	150w	A2476
Cabin Control Assy			C23175-01
150w Xenon Lamp			D8151

VAC	Lamp life	Range @ 1 Lux	PBCP X 1000	Div	Watts
24v 115/230v	1200 hrs	2465m	6.000	1.5°	150w