



LX300RC Issue 5  
Xenon 300w,  
Remote Control.

## APPLICATION

The FRANCIS LX Premium range of variable speed Remote Controlled Searchlights incorporate the design features required to successfully operate searchlights in the most demanding product operating environments on land and sea.

Francis Searchlights have developed and improved all remote controlled searchlights across the range still further by adding full variable speed, a new modern and sleek joystick control panel, using membrane and LED technology, offering Bus Control.

The Francis bus (FBUS) is a custom communication protocol based on RS485 two-wire bi directional communication hardware. The system provides a simple bi directional link between searchlights and control panels.

The colour temperature of the Xenon lamp being equal to that of 'sunlight', make this the searchlight ideal for polar regions.

These high power searchlights are well suited to applications where long range and excellent light output are required. For marine applications assisting collision avoidance and man over board situations, and crucially saving lives.

The Francis Xenon searchlight is strong and very well manufactured, and hence is used extensively in security applications, including border control, prisons & watch towers.

## SPECIFICATION

- Immediate full lamp brilliance from switch on.
- Toughened super clear Optiwhite front glass.
- Parabolic super pure Glass reflector
- Constructed from marine grade materials and fixings.
- Powder coated and stove enamel paint finish.
- Pan rotation 365°.
- Tilt elevation control  $\pm 35^\circ$ .
- Variable speed LED joystick, with auto home position.
- RS485 connectivity. Dimmable Control Panel.
- Variable Rotation Speed 1 to 60°/sec (Pan).
- Variable Elevation Speed 1 to 17°/sec (Tilt).
- Heater fitted in gearbox & barrel.
- Operational temp  $-50^\circ$ .
- Remote lamp focus, 1.5° spot to 10° flood.
- Sealing - IP67 Gearbox, IP56 Searchlight.
- Searchlight weight 40kgs.
- High quality Electronic PSU suitable for 50/60 Hz 1ph
- Redesigned gearbox housing, incorporating cable termination, for direct connection to the internal Xenon PSU.

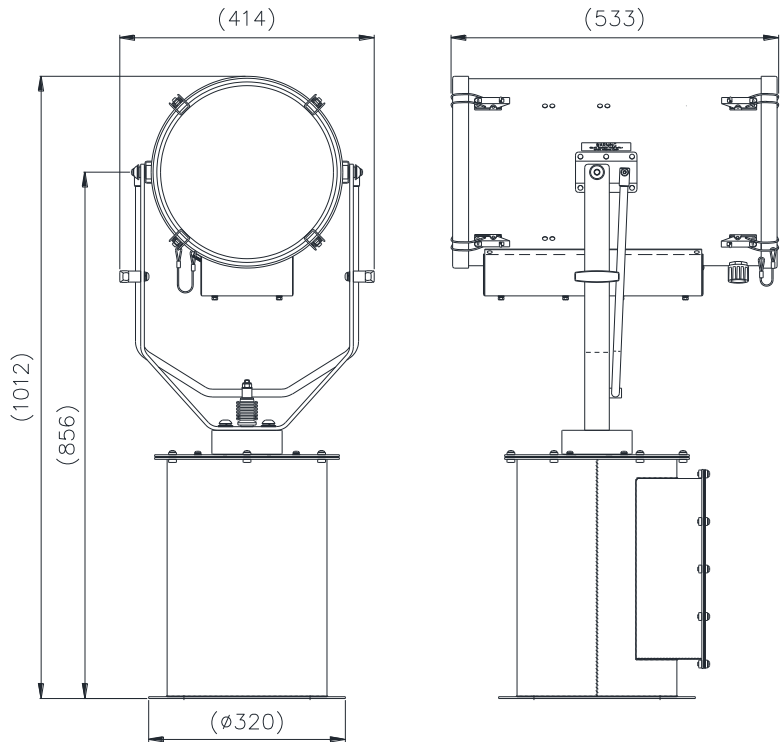

## ALL DIMENSIONS IN MILLIMETRES

Base fixing details:

4 holes 12.5  $\varnothing$  equi-spaced on a 290mm PCD

Joystick panel 120 x 120mm (106 x 106mm cutout)

## Part Numbers

Type	Supply	Watts	Part No
LX300RC	230v	300w	A7145
LX300RC	115v	300w	A7146
300w Xenon Lamp			D21908

## Optional extras:

Computer Control Software

Azimuth LED Control Panel

Master Control Panel (control up to 6 Searchlights)

Slave Control Panels (with full control)

Fiber Optic/TCP/IP Connections

Flir Thermal camera

VAC	Lamp life	Range @ 1 Lux	PBCP X 1000	Div	Watts
115/230v	1000 hrs	3487m	12,100	1.5°	300w