



**M9&M10 Issue 4
Tungsten Halogen
Manual Control**

APPLICATION

These attractive, quality built searchlights are suitable for smaller craft where good illumination characteristics, durability and appearances are important factors.

These searchlights are approved by the UK Department of Transport Marine Directorate for use on ships' lifeboats according to Chapter 111 of the 1983 amendments of the S.O.L.A.S. regulations.

SPECIFICATION

The following features are incorporated in both the M9 & M10 searchlights.

- Toughened super clear Optiwhite front glass.
- Polished, electro-brightened super purity Aluminium, parabolic reflector.
- Constructed from marine grade materials and fixings
- Powder coated and stove enamel paint finish
- Tilt elevation control $\pm 35^\circ$.
- Tungsten halogen lamp
- Sealing – IP66 Searchlight
- Searchlight weight M9 1.7kgs, M10 2.2Kgs
- Special Cabin dimensions available on request
- Fixed Focus

Performance Data * Inclusive angle

VAC	Lamp life	Range @ 1 Lux	PBCP X 1000	Div	Watts	Lamp No
12v	3000 hrs	405m	164	3.4°	50w	D4051
12v	50 hrs	576m	332	3°	50w	D9849
12v	50 hrs	640m	409	4°	100w	D3018
12v	2000 hrs	492m	242	4.6°	100w	D9848
24v	2000 hrs	438m	191	4.7°	100w	D9850

M10

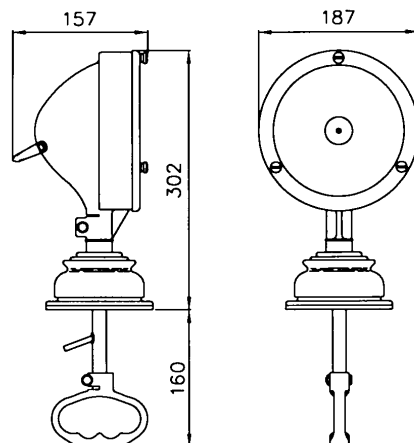

M9 Deck

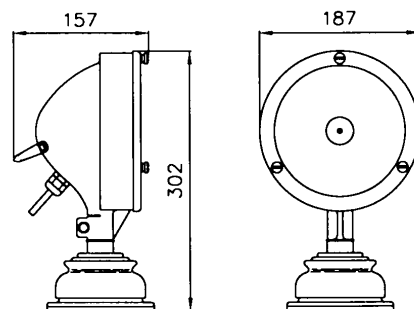

ALL DIMENSIONS IN MILLIMETRES

Base fixing details:
3 holes $\varnothing 6.4$ on a 108 P.C.D.
Under deck control clearance hole $\varnothing 45$.

Part Numbers

Type	Finish	Part No
M9	Silver	A2059
M9	White	A2060
M10	Silver	A2084
M10	White	A2085