



User Instruction & Installation Manual

LX480 Manual Control 1Kw Xenon Prison Searchlight



Product Reference Number:

- A6024 – LX480 Cabin 240v 1Kw Prison S/L
- A6025 – LX480 Cabin 115v 1Kw Prison S/L
- A6111 – LX480 Cabin Pedestal 240v 1Kw Prison S/L
- A6112 – LX480 Cabin Pedestal 115v 1Kw Prison S/L

Manufacturer's details:

Francis Searchlights Ltd
Union Road, Bolton
Lancashire, BL2 2HJ, UK
Tel: +44 (0) 1204 558960
Fax: +44 (0) 1204 558979
<http://www.francis.co.uk>
E-mail: sales@francis.co.uk

Distributor details:

Manual Part Number: **C24264**
26/3/24 Issue: 5

CONTENTS

- 1 - Introduction
- 2 - Safety Precautions
- 3 - Technical Information
- 4 - Unpacking and Installation Instructions
- 5 - Electrical Installation
- 6 - Operating Instructions
- 7 - Fault Finding
- 8 - Maintenance and Servicing
- 9 - Wiring Diagram & General Assembly
- 10 - Spare Parts List

1 – Introduction

It is imperative that this manual is read carefully and understood before installing your equipment. For your future reference please keep this manual in a safe place.

Thank you for specifying a product from the Francis Searchlights range. All Francis products are designed to give complete customer satisfaction and are manufactured to the highest engineering standards to ensure optimum performance and service life.

The Francis Xenon range combines features proven over many years service in the most hazardous conditions in both marine and land installations.

To prolong the life and performance of your product, we recommend that you only specify Francis Searchlights spare parts. This will also ensure that any warranties on your equipment will not be invalidated. Information on spares ordering and parts is provided in this manual.

Should you ever need to contact Francis Searchlights Ltd. regarding your equipment, please always quote the Product Serial Number.

2 - Safety Precautions

The following instructions must be adhered to, to ensure a safe working environment and the safety of the user.

Note: When unpacking or manoeuvring the searchlight into its fixing position, suitable lifting points must be used to prevent damage to the equipment or personal injury.

- Because of the high internal pressure within the lamp, there is a risk of explosion in either a hot or cold state.
- During operation, this lamp emits intense UV radiation which is harmful to the eyes and skin. Suitable protection should be worn.
- The high luminance of the arc can cause severe damage to the eye if viewed directly. ALWAYS wear suitable protective goggles when viewing the lamp.
- Always use protective jackets supplied with the lamp.
- Should it be necessary to examine the lamp with the front bezel removed, always use a protective shield and wear goggles to ensure a safe working environment.
- Searchlights get hot. Never touch the unit when lit and always allow 15 to 20 minutes for cooling down after turning the searchlight off.
- Never place anything on or cover the searchlight when in use.
- Ensure the lamp has cooled sufficiently before removal.
- If undue force appears necessary to remove the lamp, the equipment should be inspected by a competent person or contact the manufacturer.
- When disposing of lamps there are several options available:
 - Return the lamp, via the supplier, to the lamp manufacturer in its complete packaging.
 - Because of the cold internal pressure of the lamp is approximately 8 bar, the lamp must first be depressurised before disposal. Place the lamp, in its protective jacket, in a plastic bag and drop from a height of 1 to 2 metres onto a hard surface.
- Xenon lamps do not contain materials which are harmful to the environment and thus are not subject to special waste disposal regulations.
- Due to the vast range of lamps available it may appear possible that more powerful lamps can be used in the equipment than for which it was designed. Even when the unit will physically accept a higher wattage lamp, this substitution is not recommended and is dangerous. This action will also void any warranties on the equipment.

Always refer to the lamp manufacturer's technical data when dealing with lamps.

3 - Technical Information

This product has been designed to operate in accordance with the product specification. The LX480 1000-watt searchlight has the following features:

- All marine grade materials and fixings.
- Electronic power supply unit.
- Precision electro formed nickel reflector, bulletproof.
- Powder coated and stove enamel painted.
- Full 450° horizontal rotation.
- Vertical movement +20 to -40.
- Internal self-regulating heater.
- Instant re-strike. No cooling down time required.
- Toughened super clear Optiwhite front glass.
- Immediate full lamp brilliance from switch on.
- Sealing – IP56 Searchlight, IP56 PSU.
- Weight – Cabin 52Kgs – Cabin Pedestal 70Kgs – PSU 14Kgs.

The searchlight also performs to the following optical data:

- Xenon light source.
- Lamp Wattage - 1000 Watts.
- Supply voltage – 115v or 240v.
- Peak Beam Candlepower – 77,000,000 lux.
- Range – 8,775 metres.
- Lamp life 3000 hours.
- Divergence - 1.5° spot to 10° flood.
- Temperature range: -50°C.

In order that the searchlight operates correctly it is imperative that competent personnel are responsible for the installation, operation, and servicing of this equipment. Failure to adhere to this advice may cause premature failure or incorrect operation of the searchlight, which may damage the equipment or cause personal injury.

Technical information on the Power Supply Unit and Ignitor are included overleaf. For more detailed information please contact the manufacturer.

PSU ref.: ECG 1000 XE
Ignitor ref. ZG 60 XE

ECG 1000 DC-C

Type HBX 1000

Electronic Control Gear for DC short arc lamps up to 1000W

Please read this information carefully, before installing and operating the power supply



-All rights reserved-

Suiting igniters

- ZG 60Xe 60Amps igniter with asymmetric ignition for Anode or Cathode Ground operating.
- ZG 120Xe 120Amps igniter with asymmetric ignition for Anode or Cathode Ground operating.

Features.

Power supply for xenon filled short arc lamps, DNVGL-CG 0339 certified.
Designed for xenon short arc lamps rated up to 1000W 66A.
Output power customer selectable by control Voltage 0-5V.
Capable to drive lamp voltage ranges from 15 to 29V.
Ballast boards inside IEC(UL) 60601 certified and HALT tested.
Input voltage range 90V AC to 264V AC, power factor corrected, built in EMI filter, meets CE and FCC part 'A'.
 μ P controlled, digital power management with high output stability over lamp lifetime.
Output short circuit protected and 'Arc to Ground' protected.
Operation with Cathode or Anode to Ground/PE possible.
Galvanic separation of lamp output and line input, thermal shut off at 90°C.
Shut off function for end of life and lamp fail parameter.
Ballast cascadable for use for higher wattage Xenon lamps.
Auxiliary regulated 24V 0.2A output for subsystems, permanent available.
For OSRAM, Ushio, Luxtel, Excelitas, PerkinElmer lamps.
Flexible Design, new lamps, and functions adaptable by software.

ELECTIRCAL DATA

All values are valid at 25 ±5°C, unless otherwise noted.

Input Data

Nominal Operation	Symbol	Unit	Nominal	Tolerances	Remarks
Input voltage AC Line	U	V AC	100-240	90 - 264	
System wattage	PL1	W		600-240	Depends on select
Input current	IL1	A		5-14	Depends on select
Line frequency	Fin	Hz	50/60	47-63	
Line Power factor	PFC	1	1.0	0.92 to 1.0	
Line inrush current limiting	A peak		13		Limiting Element will be shorted by Relay
Leakage Current to PE	I Leak_SA	µA	<500@230V		Standalone

Other Operation Data	Symbol	Unit	Nominal	Tolerances	Remarks
System wattage during ignition	P ign	W	25	<30	
System wattage standby operation	P LISTby	W	1,5	0.58 – 2.0	

Lamp Output Data

Ignition	Symbol	Unit	Nominal	Tolerances	Remarks
Ignition voltage with ZG Xe	U ign	KV Peak	30-35	<30	Depends on igniter
Ignition time	T ign on	Sec.	1	0.9 – 1.1	
Automatic restart counter			5	--	attempts

Run-up Operation	Symbol	Unit	Nominal	Tolerances	Remarks
Run-up Current @ 15V	I max.	A	66	+10%	Inside specified lamp parameter (Select by internal Mode switch)
Lamp voltage	I max.	A		Max	
In Rush Current	I max.	A	80		0 to 1ms

Nominal Operation	Symbol	Unit	Nominal	Tolerances	Remarks
Lamp voltage	U La	V	10 – 29	± 5%	Depends on lamp select
Lamp wattage	P La	W	1000	± 2%	Fixed factory set-up Mode #4 1000W
Lamp current	I La	A	Up to 66		Depends on set up
End of life cut off voltage	U La max.	V	30	± 1V	After run up completed
End of life cut off time	T EOL-Off	S	< 0.2		
RF ripple of output power	P La.rip / P La	%	< 1 p-p		15,5V-30V
50Hz-60Hz Ripple		%	< 1 p-p	< 4 p-p	13V 30V
Shift in output power with shift in input voltage	P La / U LI	1		< 0.005	Within nominal values
Open circuit voltage for ignition	U ocv	V	110	105 - 120	

LIFETIME DATA

All values for $U_u = 230 \text{ V mrs}$
 Temperature at test point = 70°C

	Symbol	Unit	Nominal	Tolerances	Remarks
Ballast lifetime	T Life	h	25,000	> 25,000	Acc. To MIL HCBK for nominal operation

MISCELLANEOUS DATA

Nominal Operation	Symbol	Unit	Nominal	Tolerances	Remarks
Power losses 115V 230V	P_v	W	60 – 180 45 - 160	\pm	Depends on power select
Efficiency	η	1	0.85	0.8 – 0.9	Depend on lamp current
Ambient temperature	T A	$^\circ\text{C}$	+25	-10 - +50	Noncondensing
Internal temperature. Switch off temperature	T C-Off	$^\circ\text{C}$	+90	+85 - +95	At heatsink no de-rating till switch off

Standby Mode	Symbol	Unit	Nominal	Remarks
Minimum mains shut off time for restart	T Reset	S	3	Standby mode is present when the lamp does not light. 1. When ignition has not been successful. 2. When lamp output is shorted. 3. When lamp extinguishes while running.

Geometry and Weight	Symbol	Unit	Nominal	Tolerances	Remarks
Length	l	mm	170/220/224	± 1	See drawing
Width	w	mm	132/139	± 1	See drawing
Height	h	mm	141	± 1	See drawing
Housing					Closed AL
Weight	W B	g	2660		

Wiring length	Symbol	Unit	Nominal	Tolerances	Remarks
Between igniter and lamp	L ll	mm		t.b.d.	As short as possible
Between ballast and igniter	L bl	mm	t.b.d.	t.b.d.	External igniter ZG 60Xe

Cooling method	Symbol	Unit	Nominal	Thermal situation must be checked in actual application
	Airflow	Metre per second	Built in fan	

Plugs and cables	Manufacturer / Type	Remarks / Header / Contacts
Ballast mains plug CN 1	Screwable for wires up 1.5qmm For max. input current = 14Amp	See drawing
Ballast Control interface plug	ST 1 JST / B6B-EH-A Isolated to line voltage. GND connected to PE.	See drawing
Connection Ballast to Igniter	By screw M5 and cables shoes (CU 16-5) for 16qmm	See drawing

PIN Assignment and Fuse

Connector		Signal	Status	Description
Line input CN 1	PIN 1 PIN 2 PIN 3	AC IN -L- AC in -N- PE		AC – wide range input voltage 90v-264v Safety Ground
CN 1	PIN 4 (-)	ON-OFF / GND By switch, by open collector or by control voltage 0-24v		Universal ON-OFF control input
Lamp output terminal	Copper rails, tapped with M5 for cable shoes (Cu16-5)	Plus, Minus Lamp voltage and power		Connection to external igniter ZG60Xe ZG 120Xe
Option Board terminal ST1 opto- isolated	PIN 1 PIN 2 PIN 3 PIN 4 PIN 5 PIN 6	GND/PE/CN1-Pin 4 Power control input +5V ON-OFF/CN1-Pin 5 Lamp lit feedback +24V-0.15A aux. out		GND and 24V return. Voltage or PWM control, 5V = 1000w Use for power-control potentiometer. ON-OFF input, Power On = <1V Open collector output (NPN), OK is low For external subsystems
Fuse		Fixed built in 3xT 5A 250V		CAUTION! For continued protection against risk of fire, replace only with same type and rating of fuse

Standards	
Safety and performance Certifications	UL 60601-1, IEC 60601-1 (CB) for ballast boards HBX180 CB Test, and UL must be completed with the final product
RFI (Radio Frequency Interferences)	Must be done with complete assembled project, built in EMI filter, that meets CE and FCC (A) requirements, for “B” an additional filter is recommended (must be tested with final product

Environmental Requirements	Ambient conditions	Remarks
Storage Temperature Range	-20°C - +60°C	
Operating Temperature Range	-10°C - +40°C	Depends on cooling
Humidity Range	20% - 95% non-condensing	
Altitude operating	0 FL to 10000 FL	
Altitude not operating	0 FL to 40000 FL	
Vibration operating	G rms, 5Hz to 500Hz random 10 min. x y z axis	t.b.d. not tested
Vibration not operating	G rms, 5Hz to 500Hz random 10 min. x y z axis	t.b.d. not tested
Shock operating	G rms, ½ sine wave 11ms x y z axis	t.b.d. not tested
Shock not operating	G rms, ½ sine wave 11ms x y z axis	t.b.d. not tested

Specification subject to change without notice

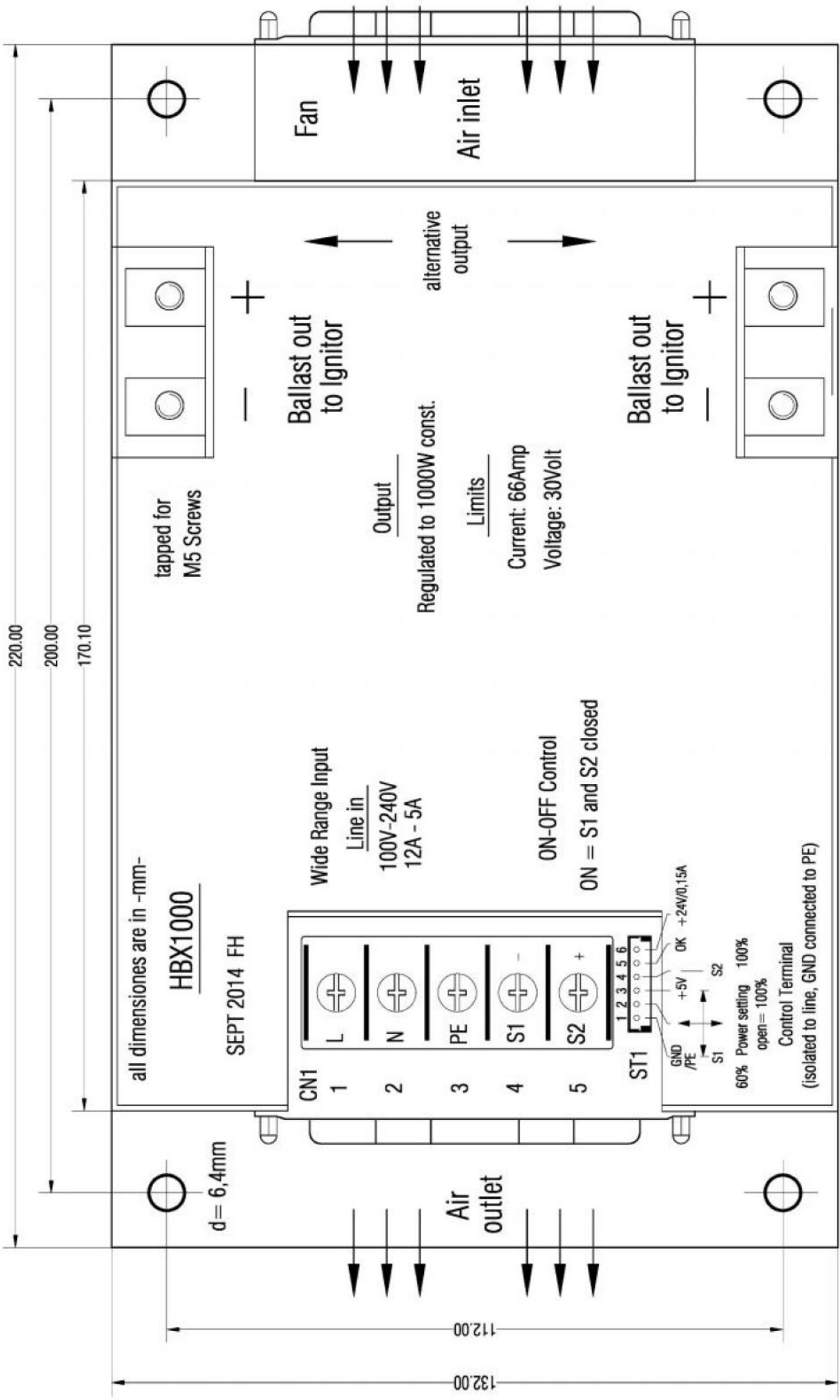

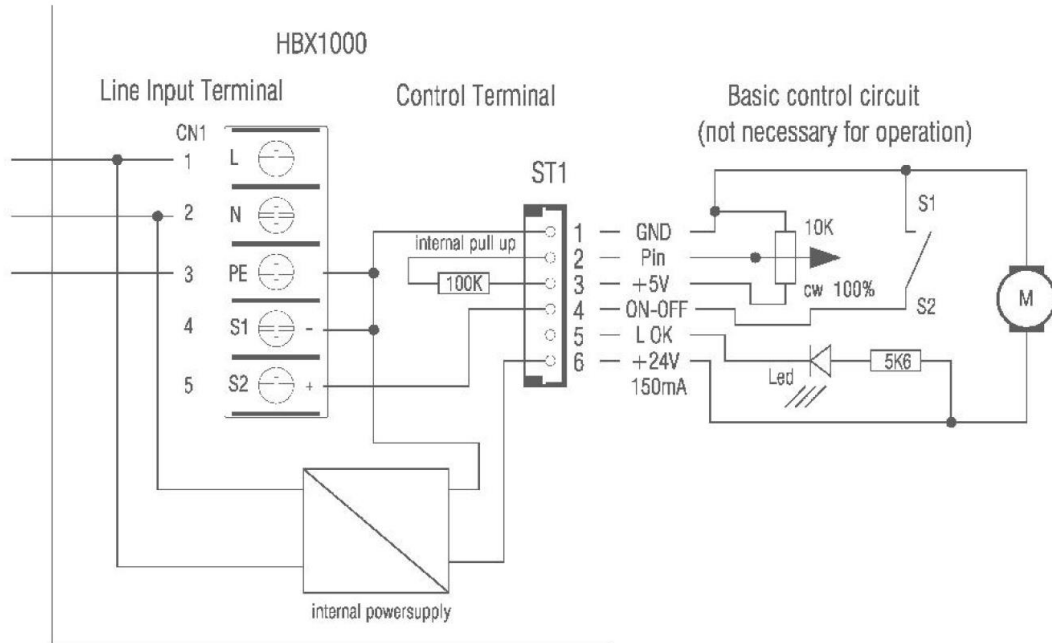

Basic circuit for use.

Pin 4 for ON-OFF is a multiple use universal input, which can be driven by signals up to 24v. To operate the lamp S1 and S2 must be closed.

PIN 3 is a high impedance input for power adjust. It can be driven by voltage between 0v and 5v PWM signals with 100Hz to 500Hz. It can be left open for 100% output power.

PIN 5 is an open collector output to drive a LED for amp OK operation.

Igniter connection



Additional information for use and safety

Safety

Because of instant hot restrike, the output voltage to the lamp can reach values of up to $\pm 15,000$ volts! Please ensure minimum 15mm clearance between all lamp terminals to PE, to prevent arc to ground situation!! Primary wiring must meet national requirements for electrical safety.

Lamp power selection

By multimode 16 step switch (O-F). Only factory setup. Not for end user.

Auxiliary 24v Output

The unit has one 24v output terminal for driving subsystems.
The maximum output current for this output is total 150mA.
The 24v output voltage is permanently available, even when the lamp is not in operation.
This terminal is connected to PE with GND (24v return).

4 - Unpacking and Installation Instructions

The following instructions should be read and fully understood prior to installing the equipment to ensure that the correct procedures are followed, and all safety precautions are observed.

Note: If the equipment has been in storage for a considerable amount of time, it is advisable to conduct a routine maintenance check on all parts before installation.

Safety Precautions

This equipment should not be connected to an electrical supply before being installed. Installation procedures should be adhered to, to ensure a safe working environment and reduce the risk of damage or personal injury.

Preparing the Mounting Position

Mark out and drill the fixing holes through the deck. Fit the 'O' ring in position and bolt the searchlight base securely. On an uneven surface it is necessary to use a suitable sealant, such as silicone, to ensure a weatherproofed joint. If anti-vibration mounts are to be fitted, the fixing holes for the mounts should also be marked out and drilled. Prior to manoeuvring the searchlight into its' fixing position, the AV mounts should be fitted to the base. When in the desired position, bolt the searchlight firmly down.

5 - Electrical Installation

For safety purposes, only competent personnel should perform the electrical installation. All equipment should be installed to current Electrical Regulations and Standards.

To obtain the maximum light output from the searchlight, it is essential that the full operating voltage of the lamp fitted be applied to the lampholder contacts.

Method of Electrical Connection

- 1) Disconnect the supply before working on the electrical system.
- 2) The searchlight must be connected to a fused electrical supply, using suitably sized cable.
- 3) If the searchlight is located a considerable distance from the supply, provision must be made in the cable size to overcome the voltage drop.

The PSU should NOT be positioned know more then 5 meters away from the searchlight.

The following table below indicates the maximum length of cable to be used for the AC supply cable, from the control panel to the searchlight:

Searchlight	115v 1Kw	240v 1Kw
Cable Size (mm ²)	Distance Max	Distance Max
1.5	17 MTRS	75 MTRS
2.5	28 MTRS	123 MTRS
4	44 MTRS	195 MTRS
6	68 MTRS	304 MTRS
10	115 MTRS	509 MTRS

- 4) Whenever possible cable terminations should be made below deck and with approved terminal devices.
- 5) If a spare auxiliary fuse or circuit breaker is not available, one of the correct type/rating should be fitted and connected to a positive supply. It is advisable to locate a bus bar or main connection and avoid any direct connection to the supply:
- 6) For 110/220v AC products, the following colour coding system should be used for the customer supply cable:

Brown - Live
Blue - Negative
Green/Yellow - Earth

Note: This equipment must be earthed.

Installation Guidelines

A typical installation and connection routine for the searchlights is as follows:

Referring to wiring diagram X4737, a 240v or 115v AC supply should be connected to the Power Supply Unit as shown, which then provides a common feed to all other functions and equipment.

Cables required to be connected by the customer: -

4 cores 4mm cable from the Searchlight into the PSU, doubling up the pairs.

4 cores 1.5mm cable from the Searchlight to the PSU.

Mains supply cable.

(Customer may need to provide a suitable junction box to extend these cables – 3 metres supplied). The searchlight head is pre-wired.

When the light is in operation the output from the PSU should be approximately 19v dc at 54amps.

Upon striking, the running wattage of the lamp can be calculated by using the equation:

$$P = VI$$

Where P= Power (watts)

V= Voltage (V)

I = Current (Amps)

Instruments required: D.C. Ammeter & Multi meter

Procedure

- 1) With the multi meter, test the DC voltage in the searchlight head. This should be approximately 19 volts.
- 2) With the D.C ammeter, test the current of the red DC cable at front of searchlight. It should read approximately 54 amps.
- 3) Multiply these readings together, as shown above, to obtain the desired wattage required, usually about 1026watts.

Fitting instructions for the 1Kw xenon lamp

Referring to the diagram overleaf:

- 1) Unfasten the eight latches on the front and rear of the searchlight.
- 2) Remove the front bezel (A) and rear bezel (B) assemblies and carefully let the bezels hang from their safety chains.
- 3) Unscrew the front lampholder lead. Unscrew the two M6 hexagon screws (C) from the front lampholder mounting block (D) and remove the front lampholder assembly from the mounting bracket.
- 4) Loosen the knurled screw (E) on the front lampholder assembly.
- 5) The lamp can now be inserted, make sure that the negative (cathode) end of the lamp is towards the rear of the searchlight and gently screw the end of the lamp into the rear lampholder socket. Do not over tighten and this may result in the lamp shattering due to undue force.
- 6) Fasten the front lampholder assembly back in position, it will be necessary to pull the front socket against its spring to fit over the lamp. When in place tighten the front knurled screw (E).
- 7) Fasten the front lampholder lead, ensuring the connections are secure.
- 8) The front bezel and rear bezel can now be replaced. Ensure all latches are securely fastened down to provide effective waterproof seal.
- 9) Removal is the reverse of the above.

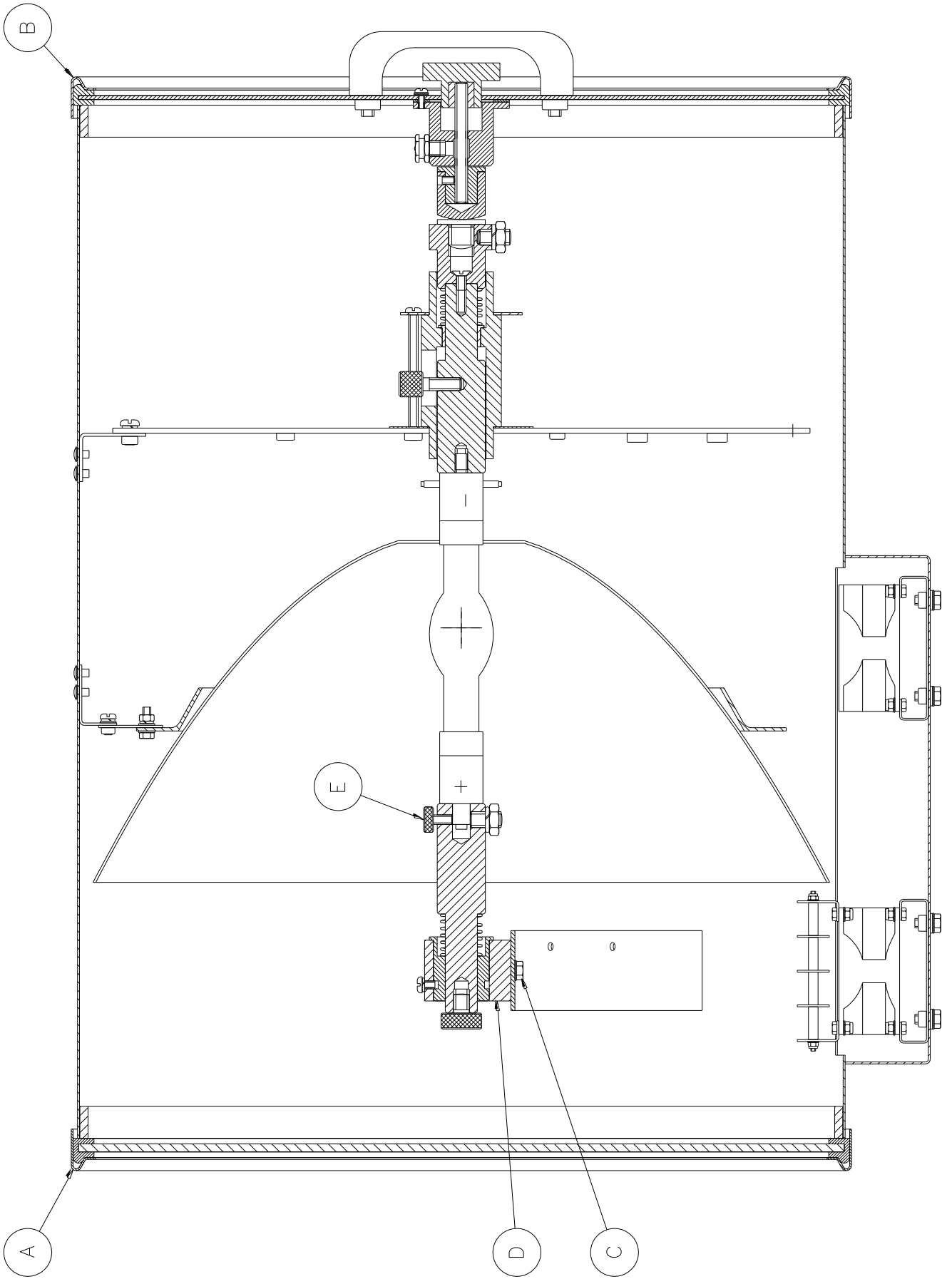

[Back To Top](#)

6 – Operating Instructions

This equipment is designed for use out of doors, in free air. Never place anything on or cover the searchlight when in use as this may present a hazard.

The PSU should be housed below deck.

The searchlight can be positioned using the elevation and base lock wheels. When in the desired position the lock wheels must be securely fastened to prevent damage.

The beam of the searchlight can be adjusted to give a variety of beam types. By turning the focus lock wheel positioned on the Rear Dome clockwise/anti-clockwise, the lamp holder mechanism moves through spot to flood positions. When the desired beam is achieved simply release the lock wheel.

The heaters specified on this equipment are self-regulating and will shut off when they reach the dew point temperature.

This product should not be used for any purpose other than for which it was designed. Any modifications to the product should not be undertaken without consulting the manufacturer.

Setting to Work

Safe service in use necessitates the strict observance of the following precautions.

- Any article fabricated from quartz or glass is inherently fragile and care should therefore be taken, always, when handling lamps.
- Eye protection must be worn when handling lamps that have been removed from their packaging materials. The protective jacket should not be removed from the lamp for safety reasons, as there is a remote possibility of the lamp shattering violently, especially if it is subjected to mechanical shock or vibration.
- Ensure that the power rating of the Xenon lamp to be fitted is suitable for the lamphouse and power supply equipment (rectifier).
- Always isolate the equipment from the supply before inserting a lamp.
- Before inserting the lamp ensure that all contacts are clean. Contacts must be renewed at the slightest sign of corrosion. Sanding or filing down corroded areas is not recommended as this will only make the conducting surface between the pin and lampholder smaller, thus causing the lamp to overheat.
- The inert gas (Xenon) used in xenon lamps are under a pressure of several bar even when the bulb is cold. FOR SAFETY REASONS THE LAMP MAY ONLY BE INSERTED INTO THE LAMPHOUSE WITH THE PROTECTIVE JACKET FITTED.
- Do not twist or bend the fused quartz bulb when fitting the lamp as mechanical stresses MUST be avoided.
- Ensure that the spring contacts firmly surround the pins on the cap of the lamp. Do not apply unnecessary force when tightening the screws.
- After inserting the lamp, ensure that there is sufficient axial play in the lampholder. The lamp must be capable of unimpeded expansion when it warms up to operating temperature. Mechanical forces must not be applied to the fused quartz bulb.
- Electrical leads must be arranged in such a way that there is a sufficient air gap (approximately 40mm) between them and the lamphouse, to prevent flashovers from the ignition voltage. All flexible leads must have strain-relieving clamps.
- Before putting the lamp into service for the first time, check the polarity of the electrical connections. INCORRECT POLARITY WILL CAUSE IMMEDIATE DESTRUCTION OF THE LAMP.
- Before the protective jacket is removed, suitable protection must be worn i.e., face mask and gloves with wrist protection.
- Never touch the quartz bulb with bare hands, as fingerprints will make the glass cloudy and cause a severe loss of light. This may also cause recrystallisation and thus weaken the bulb material. Should the bulb be inadvertently touched, remove fingerprints with methylated spirit and a clean, soft paper towel. The bulb should then be wiped with distilled water. (NOTE: ALWAYS WEAR MASK AND GLOVES DURING CLEANING).
- All packaging and the protective jacket must be retained for re-use. Whenever removing a lamp, the protective jacket must always be used for safety reasons.

Notes:

- 1) Xenon lamps are designed for dc operation only. The dc current may only be varied within the limits of the current control range. Xenon lamps operate best at rated current; over the life of the lamp, the current may be increased to its maximum value to compensate for loss of light. The output of the lamp can be reduced by operating the lamp at minimum current, but this does not prolong the life of the lamp.
- 2) For safety reasons, Xenon lamps should be replaced once they reach the end of their average lamp life, and not later than 1.25 times their average lamp life. After this time there is an increased risk of the lamp exploding.
- 3) The anode (positive cap marked '+') must be on top when the lamp is inserted in the vertical position. If the anode is incorrectly inserted the arc will be unstable, the bulb will blacken more quickly, and the lamp will prematurely fail.
- 4) The HT lead from the high voltage terminal of the Ignitor, must be connected to the cathode (negative cap marked '-'). If the lamp is connected with the wrong polarity it will be irreparably damaged after a very short time.
- 5) In all circumstances the lamp manufacturer's data should be referred to when dealing with lamps.

7- Fault Finding

All fault finding must be conducted by a competent person or qualified Electrical Engineer.

Please refer to the following table for the troubleshooting of Xenon lamps.

Fault	Cause	Remedy
<ul style="list-style-type: none"> ■ Wrong Polarity. 	<ul style="list-style-type: none"> ■ Lamp incorrectly fitted. ■ Faulty wiring. 	<ul style="list-style-type: none"> ■ Anode (large electrode) must always be on top in vertical burning position. ■ Check polarity, transpose connections if necessary.
<ul style="list-style-type: none"> ■ Cap overheated. ■ Cap temperature above 230°C. 	<ul style="list-style-type: none"> ■ Faulty contacts. ■ Cooling equipment defective. 	<ul style="list-style-type: none"> ■ Check terminals, tighten, or renew. ■ Check cooling equipment and replace if necessary.
<ul style="list-style-type: none"> ■ Arc unsteady. 	<ul style="list-style-type: none"> ■ Lamp operated outside current control range. ■ Magnetic stabilisation for horizontal operation defective. 	<ul style="list-style-type: none"> ■ Correct current setting. ■ Check magnetic stabilisation.
<ul style="list-style-type: none"> ■ Bulb draws in air. 	<ul style="list-style-type: none"> ■ Crack in graded seal caused by overheated cap. ■ Maximum cap temperature 230°C. 	<ul style="list-style-type: none"> ■ Check terminals - tighten or renew.
<ul style="list-style-type: none"> ■ Glass erosion on fused quartz bulb. 	<ul style="list-style-type: none"> ■ Lamp operated outside current control range. ■ Lamp service life exceeded. 	<ul style="list-style-type: none"> ■ Correct current setting. ■ Check meter.
<ul style="list-style-type: none"> ■ Electrodes damaged. ■ Premature blackening. 	<ul style="list-style-type: none"> ■ Current ripple too high. ■ Auxiliary mirror incorrectly adjusted. 	<ul style="list-style-type: none"> ■ Have power supply inspected. ■ Adjust auxiliary mirror.
<ul style="list-style-type: none"> ■ Asymmetrical blackening of lamp (in horizontal burning position). 	<ul style="list-style-type: none"> ■ Lamp operated too long in same position. 	<ul style="list-style-type: none"> ■ Turn lamp through 180° after half service life.

Failure of Lamp to Ignite

In the event of the xenon lamp failing to light the following steps should be taken:

- 1) Check that the mains supply is connected to the input of the PSU. On operating the switch, if the lamp does not light switch off mains supply and check all fuses.
- 2) If the lamp still does not ignite, check the searchlight head. On your command get an operator to activate the starting switch for approximately 5 seconds. During this time listen for any noise (cracking or hissing) coming from within the barrel. If this arcing is heard switch off the supply at the mains. Remove the rear dome to expose the two supply leads to the xenon lamp. Using a dry cloth wipe these leads to remove any dust, moisture or condensation that may have formed around the inside of the barrel. Replace the rear dome, ensuring the latches are secure, and perform the check again, listening for the cracking. If the lamp still fails to ignite, switch off at the mains and replace the xenon lamp in accordance with the safety procedures within this manual and the manufacturers' information.

Any further tests to be carried out with regards to lamp failure must be conducted by a competent electrical engineer and should not be carried out in an explosive atmosphere.

- 3) Before a xenon lamp will ignite, the electrically insulated gas between the electrodes must be ionised. This is done by the ignitor which produces a high frequency voltage (up to 32,000 volts or higher). The ignitor is activated by switching the lamp on and a crackling or hissing noise should be heard. The ignitor is housed within the rear of the searchlight barrel. This is a totally encapsulated unit and repair is not advised. If found to be faulty a new ignitor must be fitted.

8 - Maintenance and Servicing

To prolong the service life and performance of your searchlight, the following maintenance guidelines are recommended:

- Maintenance checks should be conducted before every voyage or at least every three months.
- Before checking, disconnect the equipment from the supply.
- Visually inspect the condition of the equipment.
- Any major or minor structural damage should be rectified immediately to reduce sympathetic wear.
- After inspection it may be necessary to clean the inside of the searchlight. The following procedure should be adhered to:
 - Remove the front bezel.
 - Clean the front glass inside and out using a proprietary glass cleaner.
 - Clean the reflector if required.
 - Check the reflector mounting gaskets. If signs of corrosion or damage are evident, replace, as necessary.
 - Ensure that the lampholder is free from corrosion or other damage.
 - Check earth point for conductivity.
- It is advisable to check all seals and gaskets for signs of degradation. Renew if necessary.
- Upon completing all maintenance requirements, the searchlight should be tested for full working order (approximately 20 minutes).

If in any doubt as to the correct servicing procedures to adopt please contact your distributor/agent or the manufacturer who will be able to advise the best course of action for your product.

9 - Wiring Diagram and General Assembly

Drawing Number	Description
X4737	Xenon Wiring Diagram
A6024	LX480C General Assembly Drawing
A6111	LX480CP General Assembly Drawing
C26807 / C26808	Power Supply Enclosure Assembly

FIRST USED ON
FX380
1000W
D.C.D.P.C.P

DO NOT SCALE DRAWING

THIRD ANGLE PROJECTION



11
MODIFICATION DETAILS

ISS No	MODIFICATION DETAILS	DATE & INITI
1	AS FIRST DRAWN	6.97 D.S.
2	THERMOSTAT REMOVED. NEW HEATER (EC0705)	1.99 D.S.
3	CABLE CHANGED TO 4 CORE 4mm M.T. (EC1096)	5.05
4	NEW ROTEC PSU (EC1660)	4.15 D.S.
5	TERMINAL FUSE ADDED (EC1734)	12.18 LW

STANDARD PRACTICE
Deburr all cut/machined edges
Break corners R0.25(Max) U.O.S.

Francis
SEARCHLIGHTS

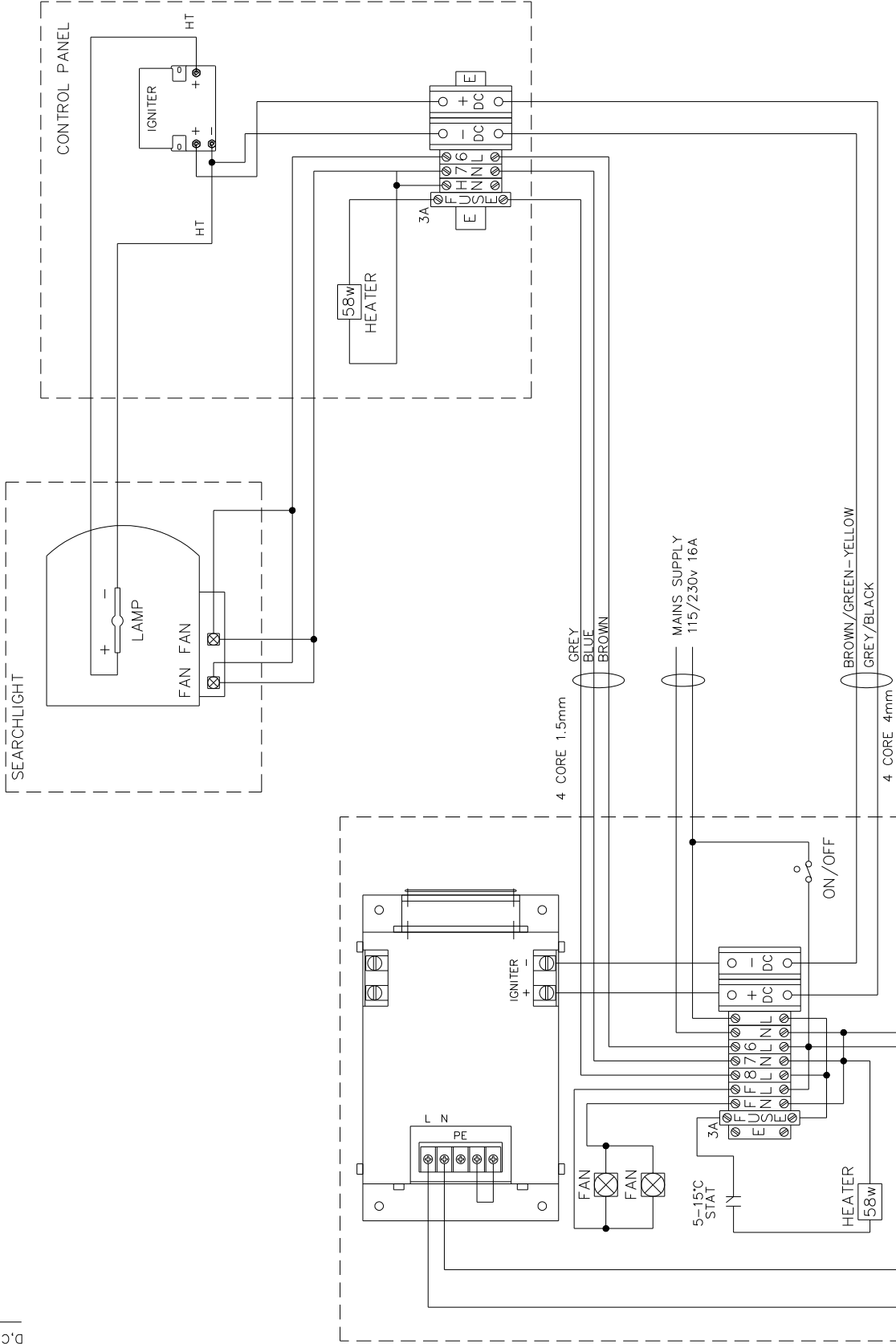

DRAWN	D.S.	DATE	5.6.97	TOLERANCES	Material	Finish	Description	
CHECKED	SCALE	General: ±					1000W XENON WIRING DIAGRAM	
ALL DIMENSIONS IN MILLIMETRES								
Hole centres & posns: ±								
Die Casting: To ISO 8062 CT10								
Sand Casting: To ISO 8062 C18								
MATERIAL								
FINISH								
DESCRIPTION								
PART No./DRG No.								X4737
SHEET								1

FRANCIS SEARCHLIGHTS LIMITED · UNION ROAD · BOLTON · BL2 2HJ

© 1997 A2 CONT ON SHEET

11

1 2 3 4 5 6 7 8 9 10 11

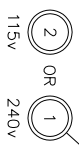
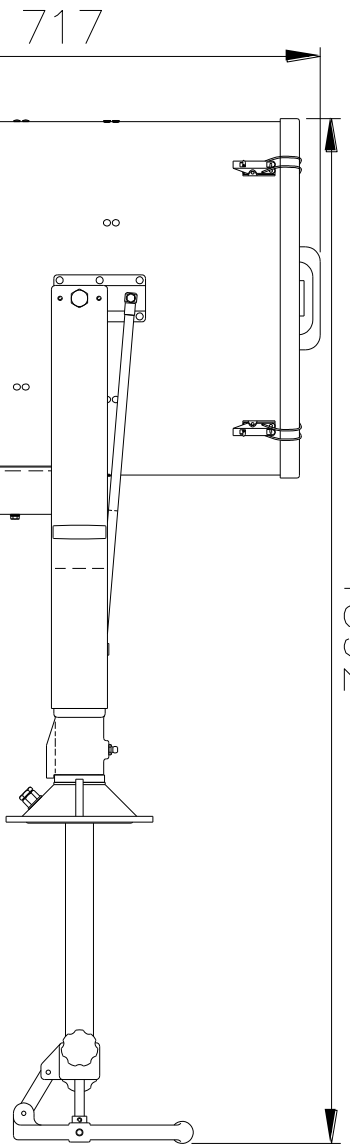

ITEM	PART No.	DRG. No.	DESCRIPTION	240v QTY	115v QTY
1	C24238	C24238	BARREL ASSY 240v	1	
2	C24239	C24238	BARREL ASSY 115v		1
3	C23791	C23791	TRAINER MOUNT	1	1

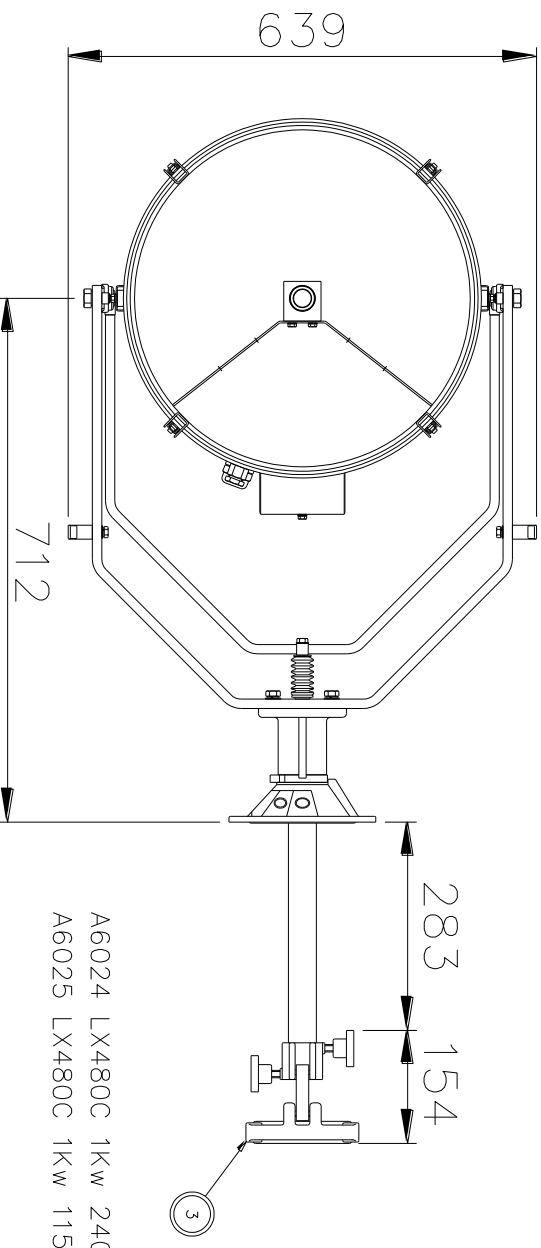

A6024 LX480C 1kw 240v GA - PRISON
 A6025 LX480C 1kw 115v GA - PRISON

STANDARD PRACTICE
 Deburr all cut/modified edges
 Break corners R0.25(Max) U.O.S.



DRAWN	D.S.	DATE	4.07	TOLERANCES	General: ±	Angular: ±	Font Coding: To ISO 8062 C/T10	MATERIAL	FINISH	DESCRIPTION	PART No./DRG No.	A2	CONT ON SHEET	SHT
CHECKED		SCALE	1:5				Die Casting: To ISO 8062 C/18			LX480C 1kw GA - PRISON	A6024	1		1
ALL DIMENSIONS IN MILLIMETRES														

FIRST USED ON

DO NOT SCALE DRAWING

THIRD ANGLE PROJECTION

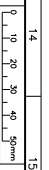

ISS No	MODIFICATION DETAILS	DATE
1	AS FIRST DRAWN	6.13 D.S.

(1766)
(1523)

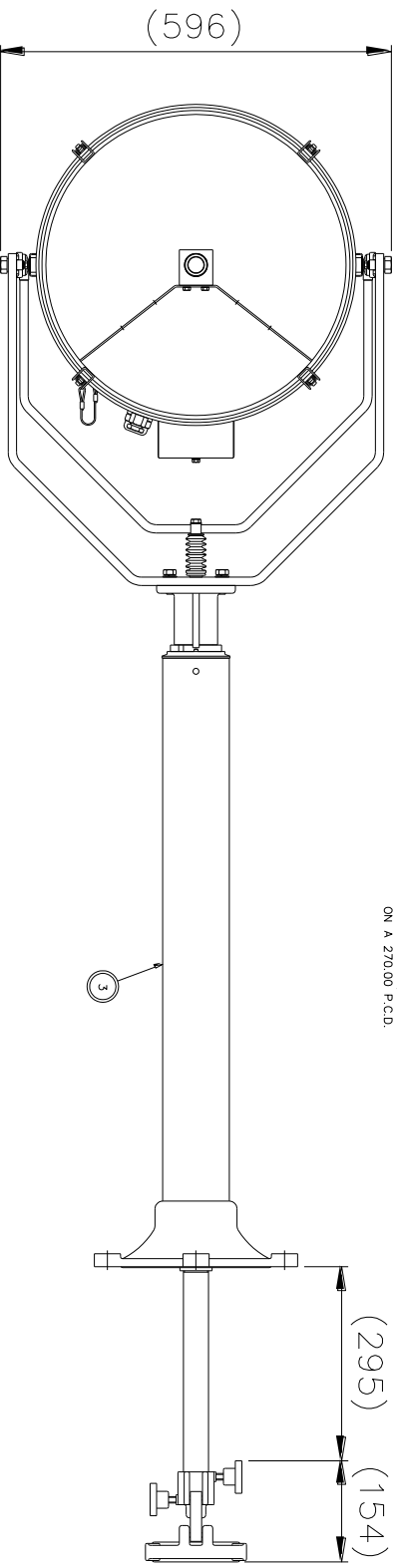
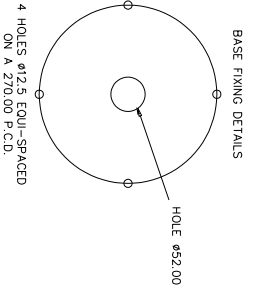
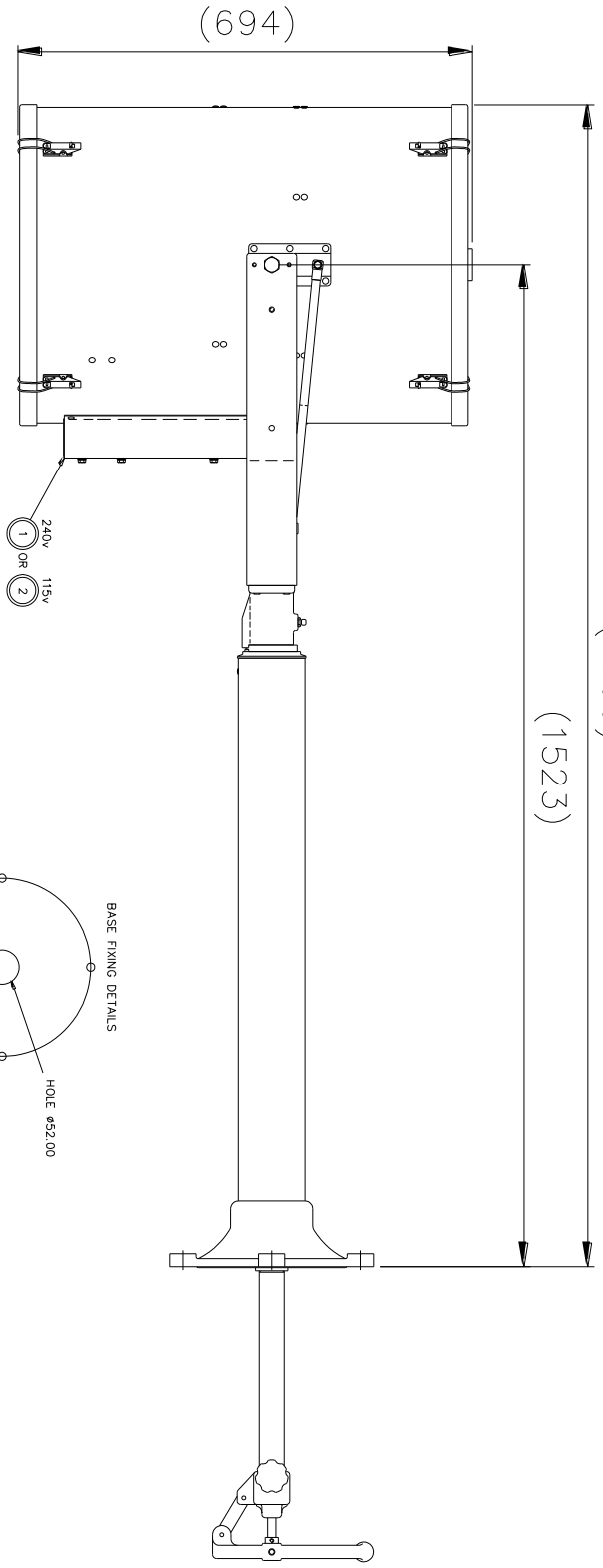

A6111 LX480CP 1KW 240V
A6112 LX480CP 1KW 115V

ITEM	PART No.	DRG No.	DESCRIPTION	QTY
1	C24238	C24238	BARREL ASSY 240V	1
2	C24239	C24238	BARREL ASSY 115V	1
3	C24042	C24042	TRAINER MOUNT	1

DRAWN	D.S.	DATE	11.6.13	TOLERANCES	Spot Centre 1: 0.05 0.02 0.10 Diam Centre 1: 0.05 0.02 0.10 Hole centre & pins 1: 0.05 0.02 0.10
CHECKED	D.S.	SCALE	1:1	FINISH	
ALL DIMENSIONS IN MILLIMETRES					
FRANCOIS SEARCHLIGHTS LIMITED . UNION ROAD . BOLTON . BL2 2HU					
DESCRIPTION LX480CP 1KW NICKEL G.A.					
©2013 A11 CONT ON SHEET PART No./DRG No. A6111 1					

STANDARD PRACTICE
Debur all cut/finished edges
Break corners R0.25(0.01) U0.35

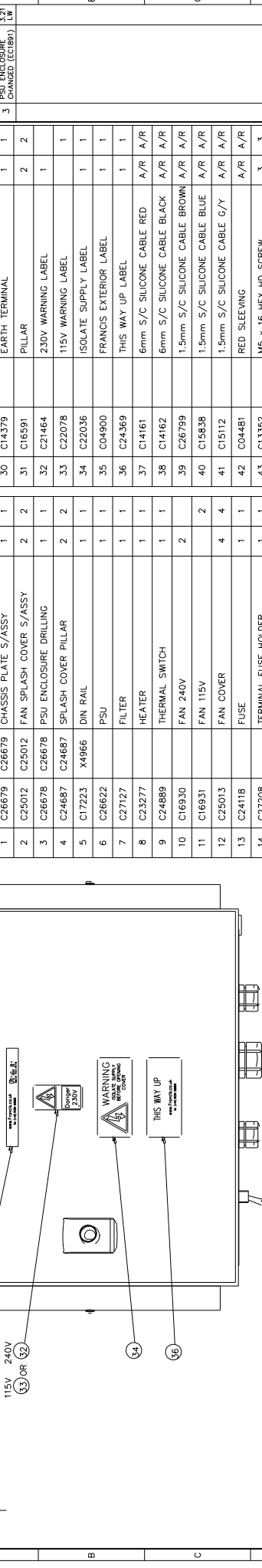

ITEM	PART No.	DRG No.	DESCRIPTION	QTY	115V	240V
1	C26679	C26679	CHASSIS PLATE S/ASSY	1	1	
2	C25012	C25012	FAN SPLASH COVER S/ASSY	2	2	
3	C26678	C26678	PSU ENCLOSURE DRILLING	1	1	
4	C24687	C24687	SPLASH COVER PILLAR	2	2	
5	C17223	X4966	DIN RAIL	1	1	
6	C26622		PSU	1	1	
7	C27127		FILTER	1	1	
8	C23277		HEATER	1	1	
9	C24889		THERMAL SWITCH	1	1	
10	C16930		FAN 240V	2		2
11	C16931		FAN 115V	4	4	
12	C25013		FAN COVER	1	1	
13	C24118		FUSE	1	1	
14	C27208		TERMINAL FUSE HOLDER	1	1	
15	C15450		M25 CABLE GLAND	1	1	
16	C10198		M20 CABLE GLAND	2	2	
17	C09880		SWITCH	1	1	
18	C21765		SEALING BOOT	1	1	
19	C27209		TERMINAL FUSE END COVER	1	1	
20	C15828		RED SHROUDED CRIMP	6	6	
21	C09299		M4 RED EYELET	5	5	
22	C27201		M6 YELLOW EYELET	2	2	
23	C02185		M5 YELLOW EYELET	2	2	
24	C10861		H/C TERMINAL	2	2	
25	C11175		H/C SPACER	3	3	
26	C10469		H/C COVER	1	1	
27	C14400		TERMINAL	7	7	
28	C15411		TERMINAL MARKERS	14	14	
29	C14139		END COVER	1	1	
30	C14379		EARTH TERMINAL	1	1	
31	C16591		PILLAR	1	1	
32	C21464		230V WARNING LABEL	1	1	
33	C22078		115V WARNING LABEL	1	1	
34	C22036		ISOLATE SUPPLY LABEL	1	1	
35	C04900		FRANGS EXTERIOR LABEL	1	1	
36	C24369		THIS WAY UP LABEL	1	1	
37	C14161		6mm S/C SILICONE CABLE RED	A/R	A/R	A/R
38	C14162		6mm S/C SILICONE CABLE BLACK	A/R	A/R	A/R
39	C26799		1.5mm S/C SILICONE CABLE BROWN	A/R	A/R	A/R
40	C15838		1.5mm S/C SILICONE CABLE BLUE	A/R	A/R	A/R
41	C15112		1.5mm S/C SILICONE CABLE G/Y	A/R	A/R	A/R
42	C04481		RED SLEEVING	A/R	A/R	A/R
43	C13352		M5 x 16 HEX HD SCREW	3	3	
44	C13351		M5 x 10 HEX HD SCREW	2	2	
45	C09895		M5 x 10 SKT BUTTON HD SCREW	2	2	
46	C10120		M4 x 20 CSK HD SCREW	6	6	
47	C06981		M4 x 16 CSK HD SCREW	7	7	
48	C14468		M4 x 35 SKT BUTTON HD SCREW	2	2	
49	C14533		M4 x 10 SKT BUTTON HD SCREW	4	4	
50	C10207		M3 x 8 SKT BUTTON HD SCREW	2	2	
51	C14502		M3 x 6 SKT BUTTON HD SCREW	2	2	
52	C08392		M5 PLAIN WASHER	7	7	
53	C09231		M5 S/C SPRING WASHER	7	7	
54	C04376		M4 PLAIN WASHER	21	21	
55	C08793		M4 S/C SPRING WASHER	19	19	
56	C08028		M3 PLAIN WASHER	2	2	
57	C10747		M3 S/C SPRING WASHER	4	4	
58	C06266		M4 FULL NUT	15	15	
59	C12039		RTV	A/R	A/R	A/R

USE ITEMS BELOW FOR WIRING

(37) (38) (39) (40) (41) (42)

C26807 1KW DECK PSU ENCLOSURE ASSY 240V

C26808 1KW DECK PSU ENCLOSURE ASSY 115V

BASE FIXINGS
340 x 260 M8 FIXINGS

FRANCIS SEARCHLIGHTS LIMITED . UNION ROAD . BOLTON . BL2 2HU

DESCRIPTION: 1KW DECK PSU ENCLOSURE ASSY

DATE: 16.03.15 TOLERANCES: ±0.10mm

SCALE: 1:2

ALL DIMENSIONS IN MILLIMETRES

GEN: 1

APP: 1

DRW: D.S.

CHEK: D.S.

ISS: No. 1

MODIFICATION DETAILS:

1	AS FIRST DRAWN	0.12
2	TERMINAL FUSE HOLDER ADDED	0.12
3	PSU ENCLOSURE CHANGED (ECT891)	1.21

DATE: 0.12.14

ISS: No. 1

MODIFICATION DETAILS:

1	AS FIRST DRAWN	0.12
2	TERMINAL FUSE HOLDER ADDED	0.12
3	PSU ENCLOSURE CHANGED (ECT891)	1.21

DATE: 0.12.14

10 - Spare Parts List

The following spare parts can be ordered directly from the manufacturer:

Part Number	Description
C26622-00	Power Supply Unit
C26623-00	Ignitor
C16930-00	Fan (240v) (PSU & Searchlight)
C16931-00	Fan (115v) (PSU & Searchlight)
D22843	1Kw Xenon Lamp
C20707-00	Front glass
C20568-00	Front glass/ Rear bezel gasket
C23277-01	Heater & Fuse Assembly
C24249-01	Reflector
C10170-00	Base 'O' Ring Seal (Cabin Pedestal)
C11148-00	Base 'O' ring seal (Cabin)
C11377-00	Focus Body Flange Seal
C20281-00	Bellows
C08926-00	Push Rod Seal
C21967-00	Bellows Bottom Bush 'O' Ring Seal
C24580-01	Tilt lock wheel assembly
C11026-01	Pan Lock wheel assembly

To prolong the life and performance of your product, we recommend that you only specify Francis Searchlights spare parts. This will ensure that any warranties on your equipment will not be invalidated.

When ordering spare parts please contact the Sales Department at Francis Searchlights Limited. Please always quote searchlight model and serial number. This will enable a fast response to your spares' requirements.