

# L230RC 45w LED Remote Control Searchlight

THE FRANCIS L230 45w LED Remote Control searchlight is part of the high-power LED range. Having been designed with the precise aim of bringing a low profile, high performing, and cost-effective LED solution to the market.

The L230RC LED has been carefully developed to withstand the extraordinary conditions while in use in the harshest of environment, such as Patrol Craft, Coast Guard and any smaller vessel application that requires a compact, lightweight, and high performer.

Within the Francis LED range of marine searchlights, the L230 LED, offers excellent efficiency utilizing Cree LED chip technology and precision lenses to give a high quality range to watt ratio, giving the ability to identify objects and potential dangers.



## Information:

- Toughened super clear Optiwhite front glass.
- High quality 5° Ledil lenses.
- Marine grade materials and fixings.
- Powder coated and stove enamel paint finish.
- Heater fitted in barrel.
- Fixed Focus.

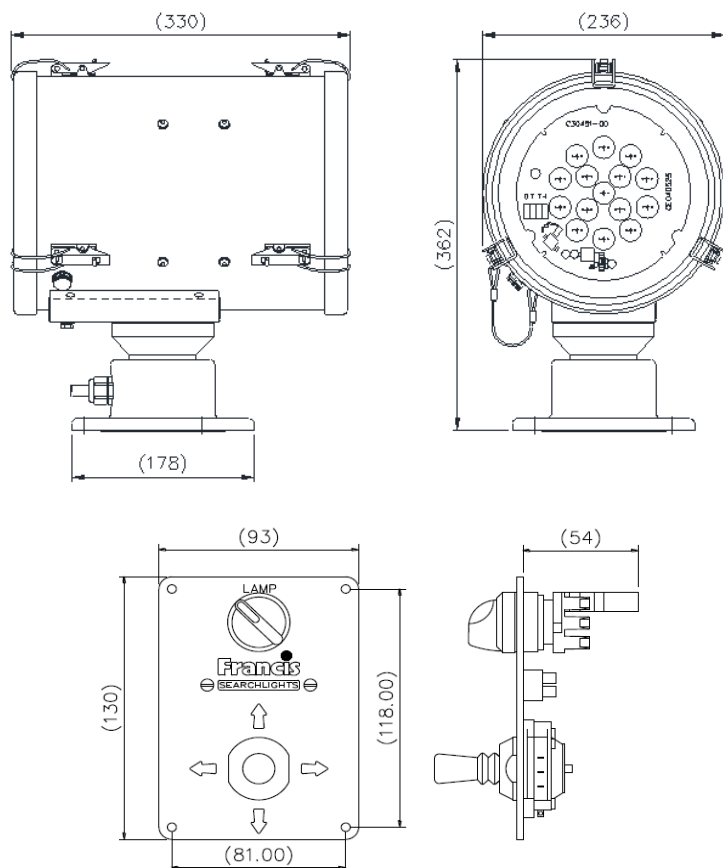

## Specification

Input voltage:	24v DC 115-240v AC
Input current:	2A Max 0.5A Max
Total power consumption:	48w Max
Searchlight H.W.D:	362 x 236 x 330mm
Weight:	10Kgs
LED power:	45w
Range @ 1 Lux:	723m
Divergence:	5°
Lamp life (approx.)	50,000h
Colour temperature:	6500K
Luminous flux:	3126 lumens
Pan rotation:	365°
Tilt elevation:	±20°
Pan speed:	24°/sec
Tilt Speed:	4°/sec
IP rating:	IP66
Operating temperature:	-20°C to +50°C
Base Fixings:	3 holes Ø11 on a 154mm PCD
Joystick Control Panel	93 x 130mm (80 x 117mm cutout)
<b>Part Numbers:</b>	
A7345 L230RC 45w 24v LED Remote Control Searchlight	
A7346 L230RC 45w 110/230v LED Remote Control Searchlight	