

The Francis Laser LED Searchlight range has been developed to offer the most powerful light source available. Using the highest grade of New Technology Laser Diode, this product offers an exceptional light output, low power consumption & in the most compact size possible.

The system uses a series of precision made glass lenses to optimize and collimate the light output, thereby achieving a greater range and illumination. The ultra compact design also benefits from being a fully integrated system, with PSU

### Information:

- Toughened super clear Optiwhite front glass.
- Precision made glass lenses.
- Marine grade materials and fixings.
- Powder coated and stove enamel paint finish.
- Special B1/2 & C2 dimensions available on request.
- Remote Focus fitted as standard.
- Control Unit On/Off & Focus.
- Anti-icing heater.
- Infrared LED Array Night Vision (Optional).
- Strobe Capability (Optional).

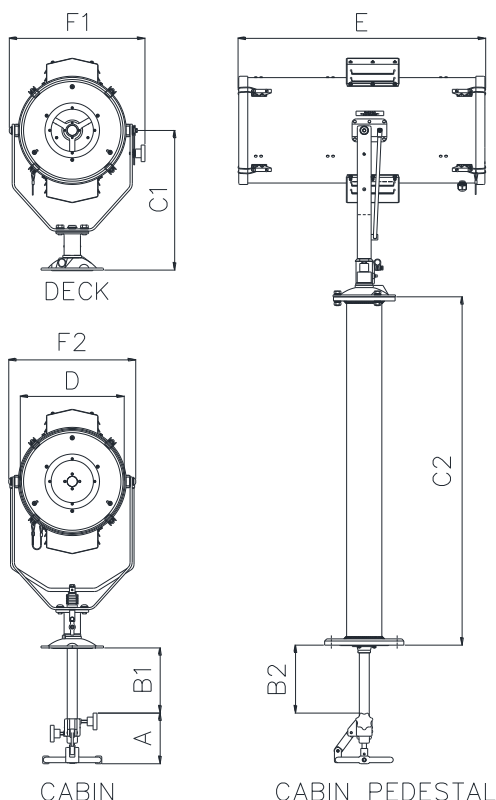

Specification		
Input voltage:	24v DC	115-240v AC
Input current:	12A Max	3A Max
Total power consumption:	350w Max	360w Max
Laser LED power:	250w	
Range @ 1 Lux:	7211m	
Divergence:	1° & 18°	
LED life (approx.)	12,000h	
Colour temperature:	6500K	
Luminous flux:	16,000 lumens	
Pan rotation:	450°	
Tilt elevation Deck/Ped:	±40°	
Tilt elevation Cabin/Ped:	+30° -25°	
IP rating:	IP56	
Operating temperature:	-20°C to +50°C	
Fixings:		
Deck & Cabin: 3 holes Ø11.0 on a 154 PCD		
Deck Ped & Cabin Ped: 4 holes Ø12.5 on a 190 PCD		
Cabin & Cabin Ped: Ø75 Centre Hole		
Part Numbers:		
A7306 L300D Deck 115/230v	A7324 L300D Deck 24v	
A7307 L300DP Deck Ped 115/230v	A7325 L300DP Deck Ped 24v	
A7308 L300C Cabin 115/230v	A7326 L300C Cabin 24v	
A7309 L300CP Cabin Ped 115/230v	A7327 L300CP Cabin Ped 24v	

Dimensions & Weights:									
A	B1	B2	C1	C2	D	E	F1	F2	
146	188	196	403	1004	300	711	392	367	
Deck 25Kgs		Deck Ped 29Kgs		Cabin 28Kgs		Cabin Ped 32Kgs			