

# L300RC 234w LED Remote Control Searchlight

The Francis L300RC 234w LED searchlight range continues to develop and offers an Efficiently and Environmentally Friendly alternative to traditional lamp sources.

Using the highest grade of LED, this range offers a high power output with low power consumption. Using a series of precision made glass lenses to optimize and collimate the light output, to achieve a greater range and output.

The Francis bus (FBUS) is a custom communication protocol based on RS485 two-wire bi-directional communication hardware.

## Information:

- Toughened super clear Optiwhite front glass.
- Precision made glass lenses.
- Marine grade materials and fixings.
- Powder coated and stove enamel paint finish.
- Variable speed, with auto home position.
- Dimmable Control Panel.
- Heater fitted in gearbox & barrel.
- Remote Focus.
- Direct cable connection to the internal LED Driver.

## Optional extras:

- Computer Control Software
- Azimuth LED Control Panel
- Master Control Panel (control up to 6 Searchlights)
- Slave Control Panels (with full control)
- Fiber Optic/TCP/IP Connections
- Flir Thermal camera
- Infrared LED Array Night Vision
- Strobe Capability

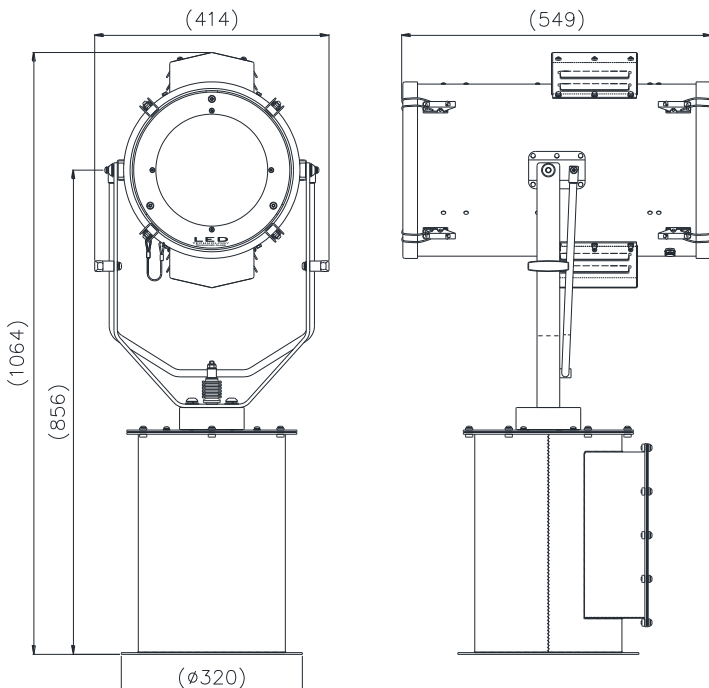

Specification	
Input voltage:	24v DC 115-240v AC
Input current:	13A Max 3A Max
Total power consumption:	320w 730w Max
Searchlight H.W.D:	1064 x 414 x 549mm
Weight:	42Kgs
LED power:	234w
Range @ 1 Lux:	3047m
Divergence:	4° - 10°
LED life (approx.)	20,000h
Colour temperature:	6500K
Luminous flux:	35,537 lumens
Pan rotation:	365°
Tilt elevation:	±35°
Pan speed:	1 to 60°/sec
Tilt Speed:	1 to 17°/sec
IP rating:	IP56
Operating temperature:	-20°C to +50°C (Optional -50°)
Base Fixings:	4 holes 12.5 Ø on a 290mm PCD
Joystick Control Panel	120x120mm (106 x 106mm cutout)
Part Numbers:	
A7179 L300RC 115/240v 234w LED Remote Control Searchlight	
A7194 L300RC 24v 234w LED Remote Control Searchlight	