

# LX230RC Xenon Twinhead Remote Control Searchlight

The Francis LX230 Remote Control searchlight is part of the high power Xenon range. Having been designed with the precise aim of bringing a low profile, high performing and cost effective solution to the market.

The LX230RC has been carefully developed to withstand the extraordinary conditions while in use in the harshest of environment, such as Patrol Craft, Coast Guard and any application that requires a compact, lightweight and high performer.

Within the Francis LX range of marine searchlights, the LX230, utilizes a 100w xenon lamp, and has been designed to give maximum beam range and candlepower, giving the ability to identify objects and potential dangers from a far greater distance.

As an optional extra option, this unit is also available with infra-red night vision ensuring total covert surveillance.



## Information:

- Toughened super clear Optiwhite front glass.
- Parabolic formed aluminum reflector.
- Marine grade materials and fixings.
- Powder coated and stove enamel paint finish.
- Heater fitted in gearbox & optional in barrel.
- Fixed Focus.
- Integral Xenon PSU and lamp fitted as standard.
- Optional infra red filter.

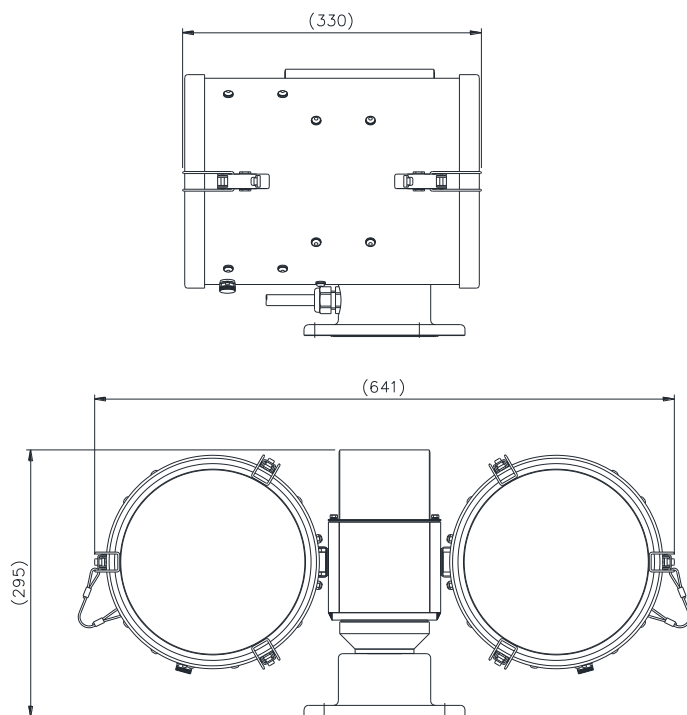

Specification	
Input voltage:	24v DC 115-240v AC
Input current:	7A Max 1A Max
Total power consumption:	1000w 240w Max
Searchlight H.W.D:	295 x 641 x 330mm
Weight:	19Kgs
Xenon power:	200w
Range @ 2 Lux:	1761m
PBCP x 1000:	6,200
Divergence:	4°
Lamp life (approx.)	50,000h
Colour temperature:	6000K
Luminous flux:	4300 lumens
Pan rotation:	365°
Tilt elevation:	±20°
Pan speed:	1 to 24°/sec
Tilt Speed:	1 to 4°/sec
IP rating:	IP66
Operating temperature:	-20°C to +50°C
Base Fixings:	3 holes Ø11 on a 154mm PCD
Joystick Control Panel	130x130mm (117 x 117mm cutout)
Part Numbers:	
A7214 LX230RC 100w 24v Xenon Remote Control Searchlight	
A7320 LX230RC 100w 115/230v Xenon Remote Control Searchlight	
D25858 100w Xenon Lamp	