

These attractive, quality built searchlights are suitable for smaller craft where good illumination characteristics, durability and appearances are important factors. These searchlights are approved by the UK Department of Transport Marine Directorate for use on ships' lifeboats.

## Information:

- Toughened super clear Optiwhite front glass.
- Polished, electro-brightened super purity Aluminium, parabolic reflector.
- Marine grade materials and fixings.
- Powder coated and stove enamel paint finish.
- Tungsten halogen lamp.
- Special Cabin lengths available on request.
- External focus control.

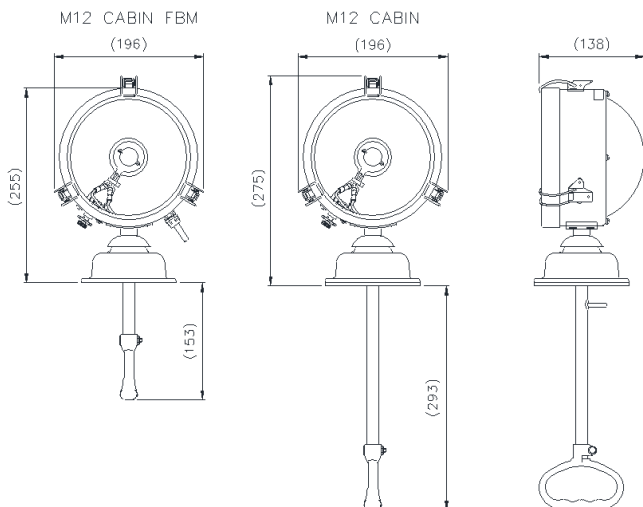
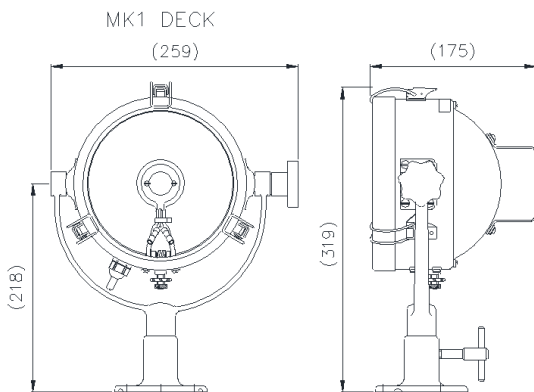

## Specification

Input voltage:	12v	24v DC
Input current:	9A	5A Max
Total power consumption:	110w	120w
Halogen power:	50w & 100w	
Range @ 1 Lux:	492m - 438m	
Divergence:	4.7°	
Lamp life (approx.)	4000h	
Colour temperature:	3000K	
Luminous flux:	1850 - 2200 lumens	
Pan rotation:	360°	
Tilt elevation:	±35°	
IP rating:	IP65	
Operating temperature:	-20°C to +50°C	

## Base Fixings:

MK1 Deck: 3 holes Ø8.0 on a 81 PCD

M12 Cabin: 3 holes Ø6.4 on a 108 PCD, Ø45 Centre Hole

## Part Numbers:

A2200 MK1 Deck White	A2204 M12 FBM Cabin Black
A2198 M12 Cabin White	

## Optional Halogen Lamps:

D9850 24v 100w	D9848 12v 100w
----------------	----------------